

Dissertation on
PREVALENCE AND PREDICTORS OF MICROALBUMINURIA
IN HIV INFECTED INDIVIDUALS

Submitted to

THE TAMILNADU DR. M.G.R. MEDICAL UNIVERISTY
CHENNAI – 600 032

In partial fulfilment of the regulations
For the Award of the Degree of

M.D. (GENERAL MEDICINE)
BRANCH -1



MADRAS MEDICAL COLLEGE AND
RAJIV GANDHI GOVERNMENT GENERAL HOSPITAL
CHENNAI – 600 003

APRIL – 2012

CERTIFICATE

This is to certify that the dissertation titled “**PREVALENCE AND PREDICTORS OF MICROALBUMINURIA IN HIV INFECTED INDIVIDUALS**” is the bonafide original work of **Dr.C.VIGNESH KUMAR** in partial fulfilment of the regulation for M.D. Branch–I (General Medicine) Examination of The Tamilnadu Dr. M.G.R Medical University to be held in APRIL 2012 under my guidance and supervision. The Period of study was from April 2011 to November 2011.

Prof. G.ELANGO VAN, MD.,
Professor of Medicine,
Guide and Supervisor,
Institute of Internal Medicine,
Madras Medical College and
Rajiv Gandhi Govt. General Hospital
Chennai – 600003.

Prof. C.RAJENDIRAN, MD.,
Director and Professor of Medicine,
Institute of Internal Medicine,
Madras Medical College and
Rajiv Gandhi Govt. General Hospital
Chennai – 600003.

Prof.V.KANAGASABAI, M.D
Dean,
Madras Medical College and
Rajiv Gandhi Govt. General Hospital,
Chennai- 600003.

DECLARATION

I, **Dr. C. VIGNESH KUMAR**, solemnly declare that dissertation titled **“PREVALENCE AND PREDICTORS OF MICROALBUMINURIA IN HIV INFECTED INDIVIDUALS”** is a bonafide work done by me at Madras Medical College and Rajiv Gandhi Government General Hospital from April 2011 to November 2011 under the guidance and supervision of **PROF. G. ELANGO VAN , MD**, Associate Professor of medicine. This dissertation is submitted to The Tamilnadu Dr. M.G.R Medical University, towards partial fulfilment of regulation for the award of M.D. Degree (Branch – I) in General Medicine.

Place : Chennai.

Date :

Dr. C.VIGNESH KUMAR

Post Graduate,
M.D. General Medicine,
Madras Medical College and
Rajiv Gandhi Government
General Hospital,
Chennai – 600 003.

SPECIAL ACKNOWLEDGEMENT

I would like to thank my beloved Dean **Prof. V.KANAGASABAI, M.D**, for having given me permission to conduct this study and allowing me to utilize the resources of Madras Medical College and Rajiv Gandhi Government General Hospital, Chennai.

ACKNOWLEDGEMENT

I would like to express my sincere gratitude to my beloved Director and Professor, Institute of Internal Medicine, Madras Medical College and Rajiv Gandhi Government General Hospital, **Prof.C.RAJENDIRAN, M.D.**, for his guidance and encouragement .

With extreme gratitude , I express my indebtedness to **Prof.G.ELANGO VAN, M.D.**, for his motivation, advice and valuable criticism which enabled me to complete this work.

I am extremely thankful to **Prof. S. RAGHUNANTHANAN, M.D.**, Additional Professor, Chief In-charge, ART Centre, Madras Medical College and Rajiv Gandhi Government General Hospital for his invaluable support.

I am grateful to my Assistant Professors **Dr.M.SHARMILA, M.D.**, and **Dr.S.DEEPA, M.D.**, for their guidance and encouragement.

I would always remember with extreme sense of thankfulness for the co-operation and criticism shown by my post graduate colleagues.

I am immensely grateful to the generosity shown by the patients who participated in this study.

CONTENT

S.NO.	TITLE	PAGE NO.
1.	INTRODUCTION	1
2.	AIMS AND OBJECTIVES	3
3.	REVIEW OF LITERATURE	4
4.	MATERIALS AND METHODS	35
5.	OBSERVATION AND RESULTS	41
6.	DISCUSSION	59
7.	CONCLUSION	66
8.	BIBLIOGRAPHY	67
9.	ANNEXURES	
	PROFORMA	85
	CONSENT FORM	89
	CERTIFICATE OF APPROVAL	90
	MASTER CHART	91

ABBREVIATION

ABC	- Abacavir
ARV	- Anti Retro Viral
ATV	- Atazanavir
AZT/ZDV	- Zidovudine
BMI	- Body Mass Index
cART	- Combination Anti-retroviral therapy
CVD	- Cardiovascular disease
DARC	- Duffy antigen receptor for chemokines
DRV	- Darunavir
EFV	- Efavirenz
eGFR _{CG}	- Estimated GFR by Cockroft Gault formula
eGFR _{MDRD}	- Estimated GFR by MDRD formula
EIA	- Enzyme Immunoassay
FPV	- Fosamprenavir
FSGS	- Focal Segmental Glomerulosclerosis
FSW	- Female Sex Worker
FTC	- Emtricitabine
HbsAg	- Hepatitis B surface antigen
HBV	- Hepatitis B virus
HCV	- Hepatitis C virus

HIV - Human Immunodeficiency Virus

HIVAN - HIV associated Nephropathy

IDU - Intravenous Drug Use

INSTI - Integrase Strand Transfer Inhibitor

IRIS - Immune Reconstitution Inflammatory Syndrome

LPV - Loprinavir

LTR - Long Terminal Repeat

MDRD - Modification of Diet in Renal Disease

MPGN - Membranoproliferative Glomerulonephritis

MVC - Maraviroc

NASBA - Nucleic acid sequence based amplification

NNRTI - Non nucleoside Reverse Transcriptase Inhibitor

NVP - Nevirapine

KS - Kaposi's sarcoma

RAL - Raltegravir

RNA - Ribonucleic Acid

RPV - Rilpivirine

RT-PCR - Reverse Transcriptase Polymerase chain reaction

RTV/r - Ritonavir

SQR - Saquinavir

TDF - Tenofovir

3TC - Lamivudine

INTRODUCTION

AIDS was first recognized in the United States in the summer of 1981, when the U.S. Centers for Disease Control and Prevention (CDC) reported the unexplained occurrence of *Pneumocystis jiroveci* and Kaposi's sarcoma (KS) previously healthy homosexual men^[1]. By 1984, it became apparent that there was a renal syndrome associated with HIV infection that was characterized by severe proteinuria and rapidly progressive renal failure^[2].

HIV infection is a global pandemic, with cases reported from virtually every country. At the end of 2009, an estimated 33.3 million individuals were living with HIV infection according to the Joint United Nations Programme on HIV/AIDS (UNAIDS). More than 95% of people living with HIV/AIDS reside in low- and middle-income countries. The global prevalence has increased approximately fourfold since 1990, reflecting the combined effects of continued high rates of new HIV infections and the beneficial (life-prolonging) impact of antiretroviral therapy^[1].

The introduction of combination antiretroviral therapy (cART) in the treatment of human immunodeficiency virus (HIV) infection has led to a substantial decline in HIV-related mortality and morbidity^[3,4]. However, it has also resulted in important short- and long-term adverse

effects ^[5]. Recent data indicate that the rate of cardiovascular disease is increased in patients with HIV infection on combination antiretroviral therapy, although the role of antiretroviral therapy and abnormalities of body composition is debated ^[6,7].

Microalbuminuria is a marker of renal damage that is associated with increased risk of cardiovascular disease(CVD) and mortality in the general population ^[8-11]. The pathophysiological mechanism underlying urinary albumin excretion and the increased risk of CVD is not fully understood, although systemic endothelial dysfunction and inflammation have been implicated ^[12,13]. There is also some evidence that microalbuminuria might represent an early indicator of HIVAN ^[14]. Thus, early detection of microalbuminuria could identify HIV-infected subjects at high risk of developing CVD and even renal diseases.

The objective of the study was to evaluate if HIV infection was an independent risk factor for microalbuminuria and second, to identify significant predictors of microalbuminuria in HIV-infected individuals.

AIMS AND OBJECTIVES

- 1). To estimate the prevalence of microalbuminuria in HIV infected individuals.
- 2). To analyse the association of Duration of HIV infection, CD4 count, Serum Creatinine, Blood pressure, Glomerular Filtration Rate and cART intake independently with microalbuminuria.

REVIEW OF LITERATURE

Since the recognition of Acquired immunodeficiency syndrome (AIDS) in 1981, in 1983, the causative retrovirus was isolated and subsequently named human immunodeficiency virus (HIV). In 1986, a second retrovirus causing AIDS, HIV-2, was identified in West Africa. It remains largely confined to this region, while HIV-1 is the cause of the world pandemic of AIDS^[15].

EPIDEMIOLOGY

GLOBAL CONSIDERATIONS

Since the beginning of the epidemic, almost 60 million people have been infected with HIV and 25 million people have died of HIV-related causes. The Global estimates for adults and children for 2009 indicates there are an estimated 33.3 million people living with HIV out of which 2.6 million are new HIV infections. AIDS accounted for 1.8 million deaths in the same year. Over 7000 new HIV infections occur in a day of which about 97% are in low and middle income countries. Among the infected about 1000 are children under 15 years of age, about 6000 are in adults aged 15 years and older, of whom 51% are women and 41% are among young people (15-24years) ^[16].

INDIAN SCENARIO

Asia is second only to sub-Saharan Africa in terms of people living with HIV. India accounts for roughly half of Asia's HIV prevalence^[16]. The epidemic in India shows a declining trend overall. HIV prevalence among adult population in 2007 was 0.34 percent and in 2008 was 0.29 percent. There is also a declining number of PLHIV in the country, with an estimated 2.27 million PLHIV in 2008 compared to 2.31 million in 2007. While there is a decline in the epidemic among FSW in south Indian states, rising trends are evident in the North East where the epidemic is increasingly driven both by IDU and sexual transmission^[17].

ETIOLOGICAL AGENT^[1,15]

HIV belongs to the family of human retroviruses (Retroviridae) and the subfamily of lentiviruses. The most common cause of HIV disease throughout the world is HIV-1, which comprises 11 sequence subtypes (or clades), A to K, of the main group M, and N (new) and O (outlier). HIV-2 too is subdivided into groups A through G each are likely derived from a separate transfer to humans from a nonhuman primate reservoir. The AIDS pandemic is primarily caused by the HIV-1 M group viruses whereas HIV-1 group O and HIV-2 viruses have caused much more

localized epidemics. The predominant clade of virus in southern Africa as well as India is Clade C.

HIV GENOME^[15]

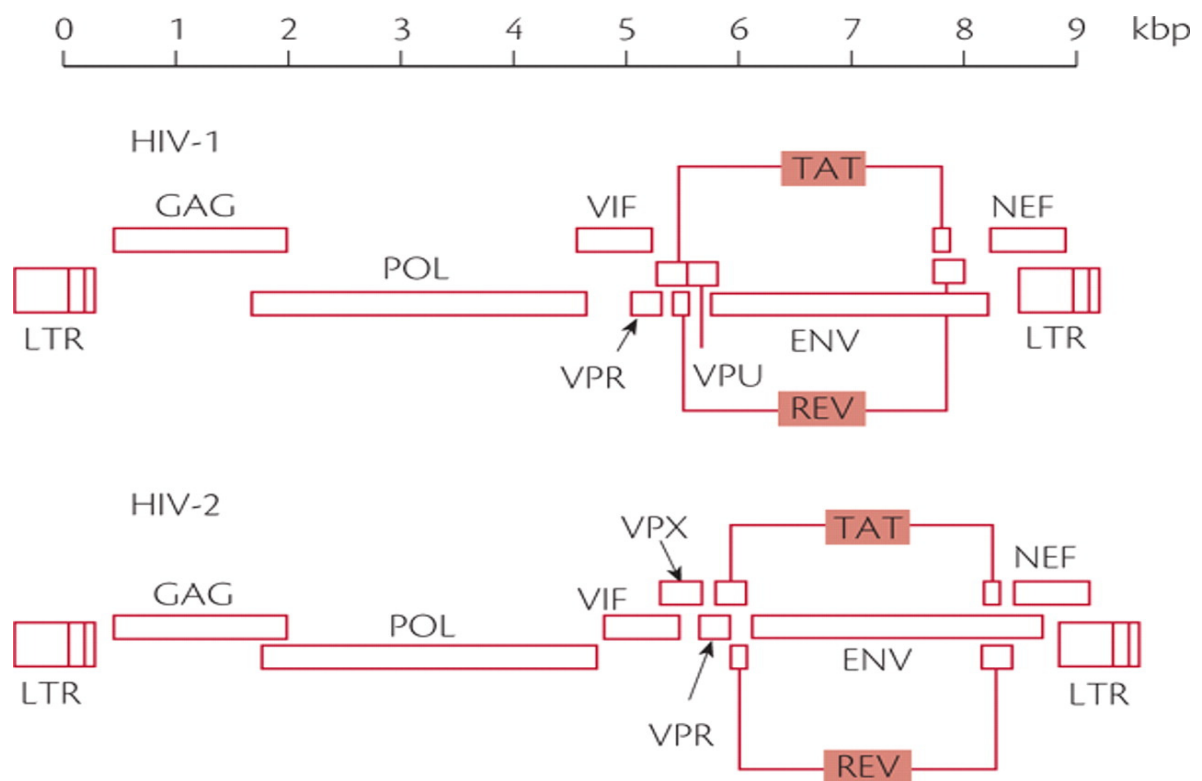

HIV has only nine genes. The three structural genes are gag, pol, and env, encoding the core proteins (p17, p24, and p15), the enzymes (protease, reverse transcriptase, and integrase), and the envelope glycoproteins (gp120 and gp41), respectively. The major regulatory genes tat and rev encode proteins that are essential for replication in the cell. The Tat

protein acts in positive feedback to enhance transcription, while the Rev protein helps the efficient transport of viral RNA from the nucleus to the cytoplasm. The functions of the four accessory genes Vif Nef Vpu Vpr of HIV are less well understood. Unlike HIV-1, HIV-2 and the simian immunodeficiency viruses (SIV) lack vpu, but have an alternative gene, vpx.

PATHOGENESIS^[1,15]

The outer envelope glycoprotein, gp120 binds to CD4 and subsequently to the coreceptor. Gp120 is anchored to the viral envelope via gp41, the viral protein that is thought to effect membrane fusion. HIV uses two major co-receptors, CCR5 and CXCR4, for fusion and entry. The mechanisms responsible for cellular depletion and immune dysfunction of CD4+ T cells include direct infection and destruction of these cells by HIV, as well as indirect effects such as immune clearance of infected cells, immune exhaustion due to aberrant cellular activation, and activation-induced cell death. Patients with CD4+ T cell levels below certain thresholds are at high risk of developing a variety of opportunistic diseases, particularly the infections and neoplasms that are AIDS-defining illnesses. High levels of MIP-1 α or - β in the blood, homozygosity for an inherited defect of the CCR5 receptor involving a

32 bp deletion in the CCR5 gene and the Duffy antigen receptor for chemokines (DARC) correlate with relative resistance to HIV infection.

DIAGNOSIS^[1]

The standard blood screening test for HIV infection is the ELISA, also referred to as an enzyme immunoassay (EIA). This solid-phase assay is an extremely good screening test with a sensitivity of >99.5%. The most commonly used confirmatory test is the Western blot . A Western blot demonstrating antibodies to products of all three of the major genes of HIV (gag, pol, and env) is conclusive evidence of infection with HIV. In case of an indeterminate Western blot, one may attempt to confirm a diagnosis of HIV infection with the p24 antigen capture assay or one of the tests for HIV RNA such as reverse transcriptase PCR (RT-PCR), branched DNA (bDNA), and nucleic acid sequence–based amplification (NASBA).

CLINICAL STAGING^[18]

WHO clinical staging of HIV disease in adults and adolescents

Clinical stage 1

- Asymptomatic

- Persistent generalized lymphadenopathy

Clinical stage 2

- Moderate unexplained weight loss (under 10% of presumed or measured body weight)
- Recurrent respiratory tract infections (sinusitis, tonsillitis, otitis media, pharyngitis)
- Herpes zoster
- Angular cheilitis
- Recurrent oral ulcerations
- Papular pruritic eruptions
- Seborrhoeic dermatitis
- Fungal nail infections

Clinical stage 3

- Unexplained severe weight loss (over 10% of presumed or measured body weight)
- Unexplained chronic diarrhoea for longer than 1 month
- Unexplained persistent fever (intermittent or constant for longer than 1 month)

- Persistent oral candidiasis
- Oral hairy leukoplakia
- Pulmonary tuberculosis
- Severe bacterial infections (e.g. pneumonia, empyema, meningitis, pyomyositis, bone or joint infection, bacteraemia, severe pelvic inflammatory disease)
- Acute necrotizing ulcerative stomatitis, gingivitis or periodontitis
- Unexplained anaemia (below 8 g/dl), neutropenia (below $0.5 \times 10^9/l$) and/or chronic thrombocytopenia (below $50 \times 10^9/l$)

Clinical stage 4

- HIV wasting syndrome
- Pneumocystis jiroveci pneumonia
- Recurrent severe bacterial pneumonia
- Chronic herpes simplex infection (orolabial, genital or anorectal of more than 1 month's duration or visceral at any site)
- Oesophageal candidiasis (or candidiasis of trachea, bronchi or lungs)

- Extrapulmonary tuberculosis
- Kaposi sarcoma
- Cytomegalovirus disease (retinitis or infection of other organs, excluding liver, spleen and lymph nodes)
- Central nervous system toxoplasmosis
- HIV encephalopathy
- Extrapulmonary cryptococcosis including meningitis
- Disseminated nontuberculous mycobacteria infection
- Progressive multifocal leukoencephalopathy
- Chronic cryptosporidiosis
- Chronic isosporiasis
- Disseminated mycosis (histoplasmosis, coccidiomycosis)
- Recurrent septicaemia (including nontyphoidal Salmonella)
- Lymphoma (cerebral or B cell non-Hodgkin)
- Invasive cervical carcinoma
- Atypical disseminated leishmaniasis

- Symptomatic HIV-associated nephropathy or HIV-associated cardiomyopathy

AIDS CASE DEFINITION^[19]

CDC AIDS case definition for surveillance of adults and adolescents

Definitive AIDS diagnoses (with or without laboratory evidence of HIV infection)

- Candidiasis of the esophagus, trachea, bronchi, or lungs.
- Cryptococcosis, extrapulmonary.
- Cryptosporidiosis with diarrhea persisting > 1 month.
- Cytomegalovirus disease of an organ other than liver, spleen, or lymph nodes.
- Herpes simplex virus infection causing a mucocutaneous ulcer that persists longer than 1 month; or bronchitis, pneumonitis, or esophagitis of any duration.
- Kaposi sarcoma in a patient < 60 years of age.
- Lymphoma of the brain (primary) in a patient < 60 years of age.
- Mycobacterium avium complex or Mycobacterium kansasii disease, disseminated
- Pneumocystis jiroveci pneumonia.
- Progressive multifocal leukoencephalopathy.

- Toxoplasmosis of the brain.

Definitive AIDS diagnoses (with laboratory evidence of HIV infection)

- Coccidioidomycosis, disseminated
- HIV encephalopathy.
- Histoplasmosis, disseminated
- Isosporiasis with diarrhea persisting > 1 month.
- Kaposi sarcoma at any age.
- Lymphoma of the brain (primary) at any age.
- Other non-Hodgkin lymphoma of B cell or unknown immunologic phenotype.
- Disseminated non tuberculous mycobacterial disease
- Disease caused by extrapulmonary M tuberculosis.
- Salmonella (nontyphoid) septicemia, recurrent.
- HIV wasting syndrome.
- CD4 lymphocyte count below 200 cells/mcL or a CD4 lymphocyte percentage below 14%.
- Pulmonary tuberculosis.
- Recurrent pneumonia.
- Invasive cervical cancer.

Presumptive AIDS diagnoses (with laboratory evidence of HIV infection)

- Candidiasis of esophagus
- Cytomegalovirus retinitis
- Mycobacteriosis
- Kaposi sarcoma
- Pneumocystis jiroveci pneumonia
- Toxoplasmosis of the brain
- Recurrent pneumonia
- Pulmonary Tuberculosis

Criteria for ART Initiation in specific populations^[20]

Target population	Clinical condition	Recommendation
Asymptomatic individuals (including pregnant women)	WHO clinical stage 1	Start ART if CD4 \leq 350
Symptomatic individuals (including pregnant women)	WHO clinical stage 2	Start ART if CD4 \leq 350
	WHO clinical stage 3 or 4	Start ART irrespective of CD4 cell count
TB and hepatitis B coinfections	Active TB disease	Start ART irrespective of CD4 cell count
	HBV infection requiring treatment*	Start ART irrespective of CD4 cell count

*The current standard definition of chronic active hepatitis is mainly based on histological parameters obtained by liver biopsy.

Preferred first-line ART in treatment-naive adults and adolescents^[20]

Target population	Preferred options*
Adults and adolescents	AZT or TDF + 3TC or FTC + EFV or NVP
Pregnant women**	AZT + 3TC + EFV or NVP
HIV/TB coinfection***	AZT or TDF + 3TC or FTC + EFV
HIV/HBV coinfection****	TDF + 3TC or FTC + EFV or NVP

* Use fixed-dose combinations

** Do not initiate EFV during first trimester

*** Initiate ART as soon as possible (within the first 8 weeks) after starting TB treatment

**** Use of two ARVs with anti-HBV activity required

ANTIRETROVIRAL REGIMEN FOR ANTIRETROVIRAL NAIVE PATIENTS^[21]

Preferred Regimens (Regimens with optimal and durable efficacy, favourable tolerability and toxicity profile, and ease of use)

➤ **NNRTI-Based Regimen**

EFV/TDF/FTC

➤ **PI-Based Regimens**

ATV/r + TDF/FTC

DRV/r (once daily) + TDF/FTC

➤ **INSTI-Based Regimen**

RAL + TDF/FTC

➤ **Preferred Regimen for Pregnant Women**

LPV/r (twice daily) + ZDV/3TC

Alternative Regimens (Regimens that are effective and tolerable but have potential disadvantages compared with preferred regimens)

➤ **NNRTI-Based Regimens**

EFV + ABC/3TC

RPV/TDF/FTC

RPV + ABC/3TC

➤ **PI-Based Regimens**

ATV/r + ABC/3TC

DRV/r + ABC/3TC

FPV/r (once or twice daily) + ABC/3TC¹ or TDF/FTC

LPV/r (once or twice daily) + ABC/3TC¹ or TDF/FTC

➤ **INSTI-Based Regimen**

RAL + ABC/3TC

Acceptable Regimens (Regimens that may be selected for some patients but are less satisfactory than preferred or alternative regimens)

➤ **NNRTI-Based Regimen**

EFV + ZDV/3TC

NVP + (TDF/FTC¹ or ZDV/3TC)

NVP + ABC/3TC

RPV + ZDV/3TC

➤ **PI-Based Regimens**

ATV + (ABC or ZDV)/3TC

ATV/r + ZDV/3TC

DRV/r + ZDV/3TC

FPV/r + ZDV/3TC

LPV/r + ZDV/3TC

➤ **INSTI-Based Regimen**

RAL + ZDV/3TC

➤ **CCR5 Antagonist-Based Regimens**

MVC + ZDV/3TC

MVC + TDF/FTC¹ or ABC/3TC

Regimens that may be acceptable but should be used with caution

➤ **PI-Based Regimens**

SQV/r + TDF/FTC

SQV/r + (ABC or ZDV)/3TC

ART SWITCHING CRITERIA^[20]

Failure	Definition
Clinical failure*	New or recurrent WHO stage 4 condition
Immunological failure**	Fall of CD4 count to baseline (or below) OR 50% fall from on-treatment peak value OR Persistent CD4 levels below 100 cells/mm ³
Virological failure***	Plasma viral load above 5000 copies/ml

* Condition must be differentiated from immune reconstitution inflammatory syndrome (IRIS). Certain WHO clinical stage 3 conditions (e.g. pulmonary TB, severe bacterial infections), may be an indication of treatment failure.

** Without concomitant infection to cause transient CD4 cell decrease

*** The optimal viral load threshold for defining virological failure has not been determined.

RENAL MANIFESTATIONS OF HIV

A causal relationship between infection and nephropathy was initially established by epidemiological studies in which epidemic or endemic infections were associated with specific glomerular abnormalities which resolves following effective treatment of the underlying infection. Viral infection may produce glomerular effects by three different mechanisms: a direct cytopathic effect of the virus on glomerular cells, stimulation of an antibody response resulting in immune complex formation, and a direct effect on T cells altering the helper-to-suppressor ratio and affecting humoral immunity. The HIV is associated with a focal segmental glomerulosclerosis (FSGS), but the case reports include large numbers of intravenous drug abusers and patients with opportunistic infections, and a direct causal relationship is difficult to establish.^[22]

The renal manifestations of HIV can be classified as

GLOMERULAR LESIONS

HIV-associated FSGS and related mesangiopathies (HIVAN)

Immune-complex-mediated glomerular diseases

- MPGN
- IgA nephropathy
- Lupus-like Glomerulonephritis

- Haemolytic uraemic syndrome/ thrombotic thrombocytopenic purpura^[23,24]

TUBULOINTESTINAL LESIONS

Acute tubular necrosis

Interstitial nephritis

Drug-related interstitial nephritis

Neoplasms including lymphoma and Kaposi's sarcoma

RENAL INFECTIONS

Pyelonephritis

Opportunistic infections such as aspergillosis , Pseudallescheria boydii, murcomycosis, adenoviruses^[25,26,27,28]

CLASSIC HIVAN

Classic HIVAN is the most commonly reported chronic renal disease associated with HIV infection.^[29,30,31,32,33] It is the third leading cause of ESRD among African Americans aged 20 to 64, following only diabetes and hypertension.^[34,35] There is a strong predilection for HIVAN among HIV-infected patients of African Heritage.^[36] Intravenous drug use has been the most common risk factor for the HIVAN, though it has been seen in all groups at risk for AIDS including homosexuals, perinatally

acquired disease, heterosexual transmission, and exposure to contaminated blood products.^[33] HIVAN usually occurs in patients with a low CD4 count. The onset of HIVAN was most common in otherwise asymptomatic HIV-infected patients.^[37,38] There is no relationship between the development of HIVAN and patient age and duration of HIV infection, or types of opportunistic infections or malignancies.^[33]

PATHOGENESIS

HIV-1 RNA was detected in renal tubular epithelial cells, glomerular epithelial cells (visceral and parietal), and interstitial leukocytes supporting a role for direct HIV-1 infection of renal parenchymal cells.^[39] The nef gene induces podocyte proliferation and differentiation that are characteristic of HIVAN. Vpr has been demonstrated to induce cell cycle arrest in the G2 phase and play a role in nuclear import of the HIV preintegration complex, transactivation of the viral long terminal repeat (LTR) promoter, and apoptosis.^[40] Host genes also play a role in the pathogenesis of HIVAN. The expression of two cyclin-dependent kinase inhibitors p27 and p57, were decreased in podocytes from HIVAN biopsies whereas expression of CDK inhibitor, p21, was increased.^[41]

PATHOLOGY

HIVAN has been termed a “pan nephropathy” because of characteristic involvement of the glomeruli, tubules, and interstitium^[42]. FSGS is the most common lesion in adults with podocyte proliferation and loss of differentiation markers, often coexisting with glomerular collapses and tubular pathology including atrophy and microcystic dilations^[22]. The interstitium shows infiltration by leucocytes, primarily CD8⁺ T-lymphocytes and macrophages. Interstitial oedema and fibrosis is frequently noted. Mesangial hyperplasia is considered as an early stage of FSGS^[30]. Though focal glomerulosclerosis are not specific, the concomitant findings of glomerular collapse, glomerular and tubular epithelial cell abnormalities, increased mesangial matrix, renal tubular atrophy or microcystic dilation, and interstitial immune cell infiltration, in combination with tubular reticular structures are virtually diagnostic of classic HIVAN^[22,29,42].

On electron microscopy, there is almost complete effacement of podocyte foot processes and the visceral epithelial cytoplasm can have large, electron-dense resorption droplets. The endothelium has large tubuloreticular inclusions located within the cisternae of the endoplasmic reticulum or the Golgi bodies^[43,44,45].

CLINICAL FEATURES

The clinical features of HIVAN include presenting features of proteinuria, typically in the nephrotic range, and renal insufficiency. Other manifestation of the nephrotic syndrome including edema, hypoalbuminemia, hypercholesterolemia and hypertension have been less common even in patients with severe renal failure.^[37,38,43,46,47,48,49] Some patients present with subnephrotic range proteinuria, and urinary sediment findings of microhematuria and sterile pyuria.^[50] The renal ultrasound in HIVAN show echogenic kidneys with preserved or enlarged size with an average of over 12 cm in spite of the severe renal insufficiency.^[38,47] Microcystic dilation is responsible for increased kidney echogenicity and size. Echogenicity may correlate with the histopathologic tubulo-interstitial changes better than the glomerular changes.^[51]

TREATMENT

HAART

The first reports of HIVAN regression was in response to zidovudine therapy ^[52,53] . The use of HAART appeared to be superior to nucleoside analog treatment alone, and appeared to account for the decreased incidence of HIVAN diagnosis. Multivariate analysis demonstrated a significantly lower progression of disease with ART^[54]. Cessation of treatment may not be safe once a diagnosis of HIVAN is made and if antiretroviral medications must be withheld, patients should be monitored for worsening renal function or proteinuria^[55]. There are reports of patients with dialysis-dependent renal failure successfully treated with HAART and repeat renal biopsies in both patients revealing resolution of the histological lesions including collapsing FSGS and tubular microcystic dilation ^[56,57].

ACE INHIBITORS

Administration of captopril to HIV-transgenic mice that exhibited characteristics of HIVAN was associated with improvement of urinary protein excretion, azotemia, and histologic abnormalities^[58]. ACE inhibitors have been shown to enhance renal survival, stabilize serum creatinine and decrease proteinuria in HIVAN and to slow the

progression to renal failure^[59,60,61,62,63]. Serum ACE levels are elevated in HIV patients and ACE inhibitors may prevent proteinuria and glomerulosclerosis by hemodynamic mechanisms, modulation of matrix production and mesangial cell proliferation, affecting HIV protease activity and by decreasing the expression of transforming growth factor beta^[58,59,61,62,63,64,65].

CORTICOSTEROIDS

Tubulointerstitial inflammation is one of the most prominent histopathologic findings in HIVAN and the inflammatory response of renal parenchymal cells to HIV infection is an important component of HIVAN pathogenesis. . A beneficial effect of steroid treatment upon tubulointerstitial inflammation has been suggested^[66]. Glucocorticoids has been found to be effective in slowing the progression of HIVAN, diminution in urinary protein excretion and improvement in renal function^[29,59,65,67,68,69,70]. But there was a relatively high frequency of side effects such as psychosis, gastrointestinal bleeding, and infections^[70]. Remissions in HIV-infected children with the minimal change pattern on biopsy treated with steroids have been noted, but not in children with sclerosing or collapsing lesions^[33].

IMMUNOSUPPRESSANTS

Limited data suggested cyclosporine ameliorated the course of the renal disease , but only few patients have been assessed and concern has been raised regarding the risk/benefit ratio of immunosuppression in patients with HIV infection^[65].

RENAL REPLACEMENT THERAPY

Early reports indicated that survival on dialysis was limited and that peritoneal dialysis seemed to be preferable. The course of therapy for dialysis patients is improving, but depends on the stage of the viral illness^[21].The current consensus is that renal transplantation is no longer a contraindication in HIV-positive patients, and outcomes have improved in HIVAN patients who received renal transplants^[71,72] and the British HIV Association have published guidelines on this topic^[73].

RENAL DISEASES RELATED TO TREATMENT

Drugs commonly associated with renal damage in patients with HIV disease are pentamidine, amphotericin, adefovir, cidofovir, tenofovir, and foscarnet. Cotrimoxazole may compete for tubular secretion with creatinine and cause an increase in the serum creatinine level. Sulfadiazine may crystallize in the kidney and result in an easily reversible form of renal shutdown^[1]. Indinavir and ritonavir , can cause

reversible nephropathy^[65,74,75]. Glomerulonephritis in HIV-infected patients may be secondary to a host response to treatment with Interferon alpha^[76].

MICROALBUMINURIA

Microalbuminuria refers to elevated urine albumin excretion that is below the level of detection by routine urine protein dipstick test.

CLASSIFICATION OF ABNORMAL URINE ALBUMIN ^[77]

	24-H Urine Albumin (mg/24 h)	Overnight Urine Albumin (µg/24 h)	Spot Urine			
			Albumin (mg/L)	Albumin/Creatinine Ratio		
				Gen der	mg/ mmol	mg/g
Normal	<15	<10	<10	M	<1.25	<10
				F	<1.75	<15
High Normal	15 to <30	10 to <20	10 to <20	M	1.25 to <2.5	10 to <20
				F	1.75 to <3.5	15 to <30
Micro albumin uria	30 to <300	20 to <200	20 to <200	M	2.5 to <25	20 to <200
				F	3.5 to <35	30 to <300
Macro albumin uria	>300	>200	>200	M	>25	>200
				F	>35	>300

Albumin excretion and microalbuminuria are currently drawing a great deal of attention due to the the fact that albumin excretion is a risk factor for kidney failure ^[78,79] , stroke ^[80,81] , and cardiovascular and all-cause mortality ^[80,82-89] , particularly for persons with diabetes and hypertension ^[86-89] . Microalbuminuria is not only an adverse factor for the progression of diabetic renal disease, but is also predictive of cardiovascular events in nondiabetic population^[90] .

PATHOPHYSIOLOGY

Albumin leakage into the urine is a reflection of widespread vascular damage^[91] . Endothelial function and chronic inflammation have been suggested as possible candidates to explain the association between microalbuminuria and CVD ^[92,93] . Low-grade inflammation can be both a cause and a consequence of endothelial dysfunction, and use of markers of inflammation such as C-reactive protein, IL-6, and TNF- α , indicate that low-grade inflammation is associated with the occurrence and the progression of microalbuminuria and with an associated increased risk for atherosclerotic disease ^[89,94,95] . Other studies indicate that although microalbuminuria, endothelial dysfunction, and low-grade inflammation are linked, they all are independently associated with risk for cardiovascular death ^[96,97] .

Some individuals are born with varying degrees of vascular function within a physiologic range and, therefore, excrete a variable amount of microalbumin ^[98] . This inherent variability of the vascular state as determined by urine microalbumin excretion may be associated with susceptibility to subsequent organ damage ^[99] . Hence microalbuminuria is a predictor of not only CVD but also new-onset hypertension and diabetes ^[99] .

SCREENING

The traditional dipstick test used to measure protein in the urine is semiquantitative and insensitive, particularly when detecting albumin concentrations <300 mg/d. A variety of antibody-based methods are available to measure urinary albumin including RIA, nephelometry, immunoturbidimetry, and ELISA. The HPLC method is more sensitive to detect microalbuminuria ^[100] . As there is a continuous relationship between the amount of urine albumin excretion and cardiovascular events, more sensitive measures may assist in the earlier identification of patients who are at risk.

An albumin-to-creatinine ratio that uses an overnight or first-morning void urine sample or measurement of albumin excretion per unit of time should be used for screening. For an untimed sample, the

albumin-to-creatinine ratio is preferred but must be corrected for the gender difference in creatinine production between men and women ^[77]. In addition, creatinine excretion in the urine depends on age and race ^[101,102]. Studies have shown first morning void may be able to replace 24-h urine collection, preferably urinary albumin concentration (UAC) in the initial screening of microalbuminuria. ^[103]

MANAGEMENT^[104]

The recommendations for management of patients with microalbuminuria include

- Renoprotection with ACE inhibitors or angiotensin receptor blockers for patients with diabetes
- BP control
 - <140/90 mmHg for the general population
 - <130/80 mmHg for patients with diabetes
- Glycemic control: hemoglobin A_{1c} <7%
- Consider screening in patients with diabetes
- LDL cholesterol control for diabetes in the general population
 - <100 mg/dl (<2.6 mmol/L) for patients with or without diabetes
 - <70 mg/dl (<1.8 mmol/L) for patients with CVD

- Correct disturbances in triglyceride, HDL, and non-HDL cholesterol levels
- Smoking cessation
- Dietary limitation of salt (<3 g/d) and saturated fat
- Regular exercise and weight control
- Antiplatelet therapy

Screening for Microalbuminuria can help clinicians estimate a patient's CVD risk prompt the early introduction of a multifactorial intervention strategy that aim to improve the overall CVD risk factor profile as well as prevent further loss of renal function.

HIV AND MICROALBUMINURIA

The prevalence of microalbuminuria is found to be multi fold higher in HIV infected individuals compared to general population in various Studies. Many significant predictors including Female gender, BMI, Clinical Stage, CD4 count, Duration of HIV have been observed to predict microalbuminuria. The aim of this study is to conduct a similar study in our population and to analyse the effect of ART on microalbuminuria.

MATERIALS AND METHODS

STUDY POPULATION

A total of 187 HIV infected patients who attended ART clinic as out-patients and admitted in the wards of Institute of Internal Medicine, Rajiv Gandhi Government General Hospital, Chennai as in-patients were screened. 100 patients were selected who fit into the study based on inclusion and exclusion criteria. Written consent was obtained from them in the prescribed format after clearly explaining to them the purpose and methodology of the study. They were subjected to a routine clinical examination and basic laboratory investigations. Urine microalbumin was estimated from their early morning urine samples. 50 people who satisfied the inclusion and exclusion criteria were selected as control population and their urine microalbumin was estimated.

STUDY DURATION

The study was conducted from a period from April 2011 to November 2011.

STUDY DESIGN

This is a cross-sectional study to evaluate the prevalence of microalbuminuria among HIV infected individuals and to analyse its association with Duration of HIV infection, CD4 count, Serum

Creatinine, Blood pressure, Glomerular Filtration Rate and cART intake independently.

Ethical Committee Approval	: Obtained
Informed Consent	: Obtained
Conflict of Interest	: There was no conflict of interest
Financial Support	: Nil

METHODS

History

A detailed history was taken from all patients which includes mode of detection, symptoms at the time of initial presentation, duration of HIV, ART intake, present complaints if any, symptoms of burning micturition, antibiotic intake, history of Tuberculosis and treatment for the same, smoking and intravenous drug-abuse habits, and knowledge of hypertension, diabetes, and cancer and hepatitis B and C status. Those who satisfied the inclusion and exclusion criteria were taken into the study group.

Examination

A detailed general examination and systemic examination was performed on all the patients. Blood pressure was measured using

sphygmomanometer twice 2 minutes apart using an appropriate cuff after the patient had rested in a sitting position for 5 minutes in a quiet room. The average of these measurements in duplicate was used for statistical analysis of systolic blood pressure (SBP) and diastolic blood pressure (DBP). Height and weight were measured to estimate the body mass index (BMI) in kg/m^2 . The detailed general examination was intended to specifically look for the presence of pallor, lymphadenopathy, pedal edema, stigmata of Tuberculosis, angular cheilitis, oral ulcerations, ulcerative stomatitis, gingivitis or periodontitis, oral candidiasis, oral hairy leukoplakia, Herpes zoster, Papular pruritic eruptions, Seborrhoeic dermatitis, Fungal nail infections, Genital ulcers and Kaposi sarcoma. A thorough Cardiovascular, Respiratory, Per abdomen and Central Nervous system examination including fundus was performed. Based on clinical examination the disease was staged according to WHO clinical staging of HIV disease in adults and adolescents.

Laboratory Investigations

A Complete haemogram, Renal function tests, Liver function tests, Urine routine analysis including albumin, sugar and deposits, ECG in all leads and Chest X ray were performed. The CD4 count, HbsAg and Anti HCV status were recorded from the existing database. An Ultrasonogram abdomen was done to assess the renal size and echoes. A quantitative

determination of microalbumin in urine was done by turbidimetric immunoassay in patients who had nil, trace or 1+ albuminuria by dipstick assay in a early morning spot urine sample. Those who had microalbuminuria by spot urine albumin concentration were confirmed by 24 hour urine albumin estimation. Those who were found to have macroalbuminuria were excluded from the study.

Creatinine clearance was calculated by Cockcroft-Gault formula using age, sex, body weight and serum creatinine values. Estimated Glomerular filtration rate was calculated by MDRD (Modification of Diet in Renal Disease) formula using age, race, sex and serum creatinine values.

Control Population

Healthy control population was selected based on inclusion and exclusion criteria . A brief history including a history of Diabetes mellitus, Systemic hypertension or any other co-morbid illnesses were elicited. Clinical examination was done including the measurement of height, weight and blood pressure as described above for cases. Basic blood investigations including Complete haemogram, Renal function tests, Liver function tests and urine routine analysis were performed. Quantitative determination of urine microalbumin was done in early morning spot urine samples of those who had nil, trace or 1+ albumin by

dipstick assay. Creatinine clearance and estimated GFR were calculated as described above.

Interpretation of Results

Reference curve was generated by successive 1:2 dilutions of the microalbumin calibrator in saline and the reference range established in our laboratory was 0-25 mg/L. A concentration above 25mg/L was considered as microalbuminuria.

INCLUSION CRITERIA

Patients who are recently diagnosed or are known HIV positive individuals either on Anti-Retroviral therapy or on pre-ART treatment attending ART clinic as out-patients or admitted as in-patients in the wards of Institute of Internal Medicine, Rajiv Gandhi Government General Hospital.

EXCLUSION CRITERIA

1. Age above 65 years
2. Diabetes mellitus
3. Systemic Hypertension
4. Documented Chronic kidney disease
5. Intake of nephrotoxic drugs

6. Febrile illness including urinary tract infection
7. Hepatitis B co-infection
8. Hepatitis C co-infection

STATISTICAL ANALYSIS

Statistical analysis was carried out for 100 patients after categorizing each variable – Age, Sex, Duration of HIV, ART intake, Clinical stage, Systolic blood pressure, Diastolic blood pressure, Serum creatinine, Creatinine clearance, eGFR and Microalbuminuria were analyzed. Data were analysed using Statistical package- SPSS software version 11.5. The significance of difference between the proportions was indicated by the chi-square (χ^2) statistic. The significance of difference in mean between the groups was calculated by student t-test. Variables were considered to be significant if ($P < 0.05$). Intervariate analysis was done by using Pearson's r- value correlation.

OBSERVATION AND RESULTS

- A total of 100 seropositive patients were included in the study and 50 age and sex matched people constituted the control population.
- Out of the 100 seropositive individuals 50 were males and 50 were females.
- 50 patients were in the Pre-ART group and 50 belonged to the ART group.
- The mean age of control population was 36.14 ± 7.36 years and that of cases was 35.99 ± 8 years.
- The mean BMI of control population was 22.95 ± 3.90 and that of cases was 22.30 ± 4.47 kg/m²
- Microalbuminuria was present in 2 out of 50 controls and 24 out of 100 cases.
- The mean Urine microalbumin level in seropositive cases was 38.07 ± 48.78 compared to that of controls who had a mean of 14.28 ± 8.35 mg/l
- The mean age of Pre ART group was 34.48 ± 7.68 years and that of ART group was 37.50 ± 8.12 years.
- The mean BMI of Pre ART group was 23.70 ± 4.81 and that of ART group was 20.91 ± 3.64 kg/m² which is a statistically significant reduction.

- Microalbuminuria was present in 17 out of 50 patients belonging to the Pre ART group and 7 out of 50 patients belonging to the ART group.
- There was statistically significant decrease in Urine microalbumin levels in patients belonging to ART group (Mean of 28.41 ± 36.31 mg/l) compared to Pre ART group (Mean of 47.74 ± 57.44 mg/l).
- Of the 100 patients 69 belonged to Stage I, 13 belonged to Stage II, 13 belonged to Stage III and 5 belonged to Stage IV.
- There was statistically significant difference in the means of Systolic blood pressure, Duration of HIV, CD4 count, eGFR calculated by Cockcroft Gault and MDRD formulae between patients who did not have microalbuminuria and those who had microalbuminuria.
- No statistical significance was found with Age, BMI, Stage, Diastolic blood pressure and Duration of ART with microalbuminuria.
- Significant negative correlation was observed between CD4 count, eGFR calculated by Cockcroft Gault and MDRD formulae and Urine microalbumin level.
- Significant positive correlation was observed between Systolic blood pressure and Urine microalbumin level.

➤ No significant correlation was observed between Age, BMI, Duration of HIV ,Diastolic blood pressure and Urine microalbumin levels.

POPULATION CHARACTERISTICS

AGE DISTRIBUTION

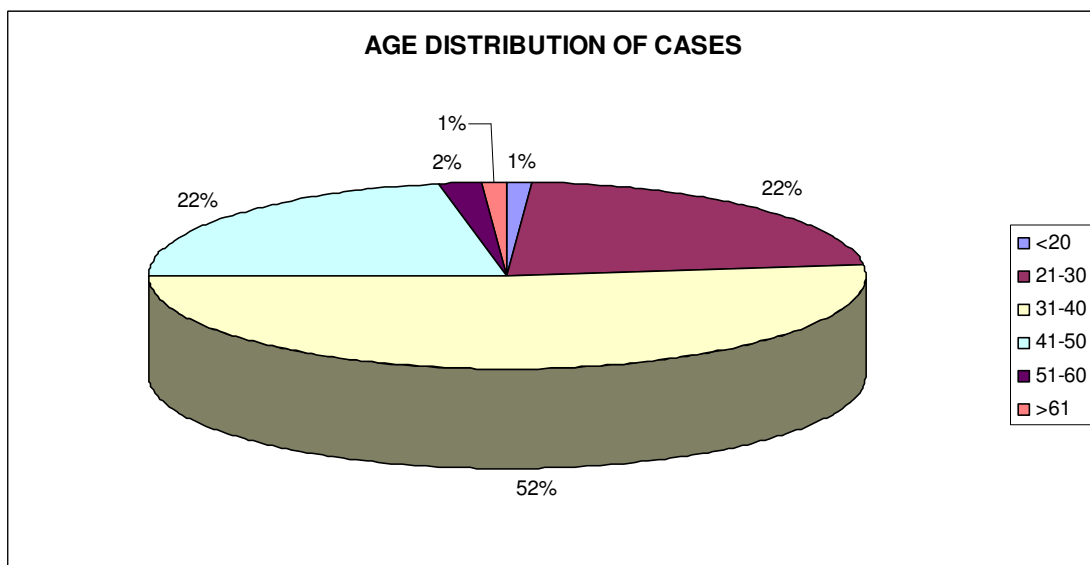
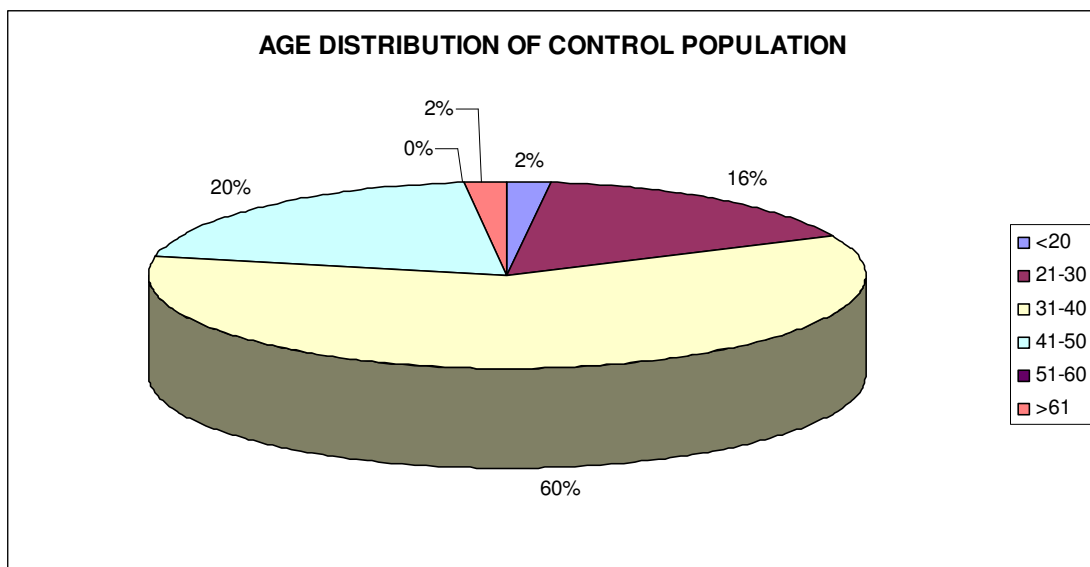

SEX DISTRIBUTION

	CONTROL	CASES
MALE	25	50
FEMALE	25	50
TOTAL	50	100

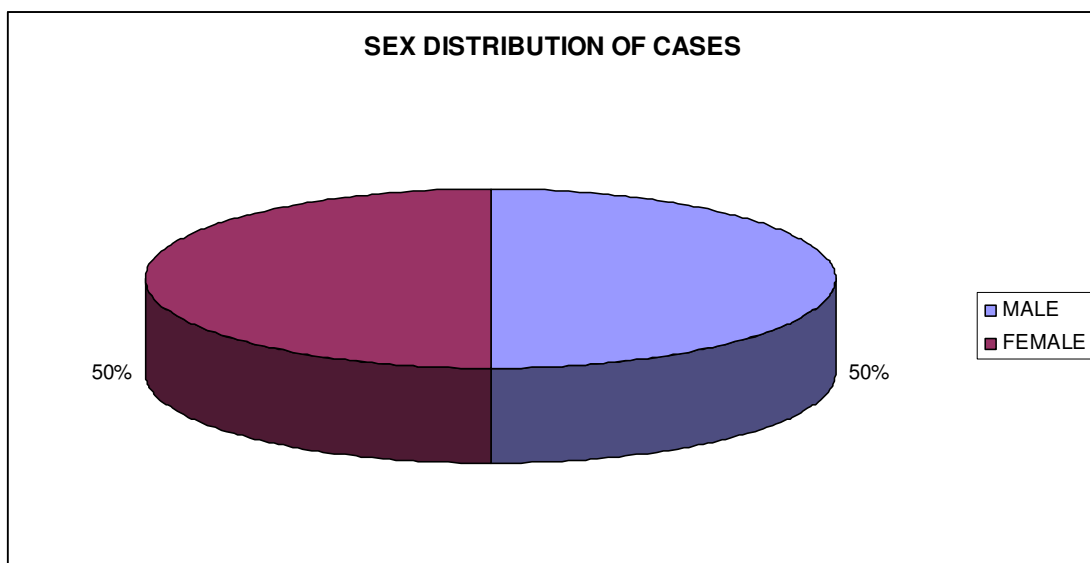
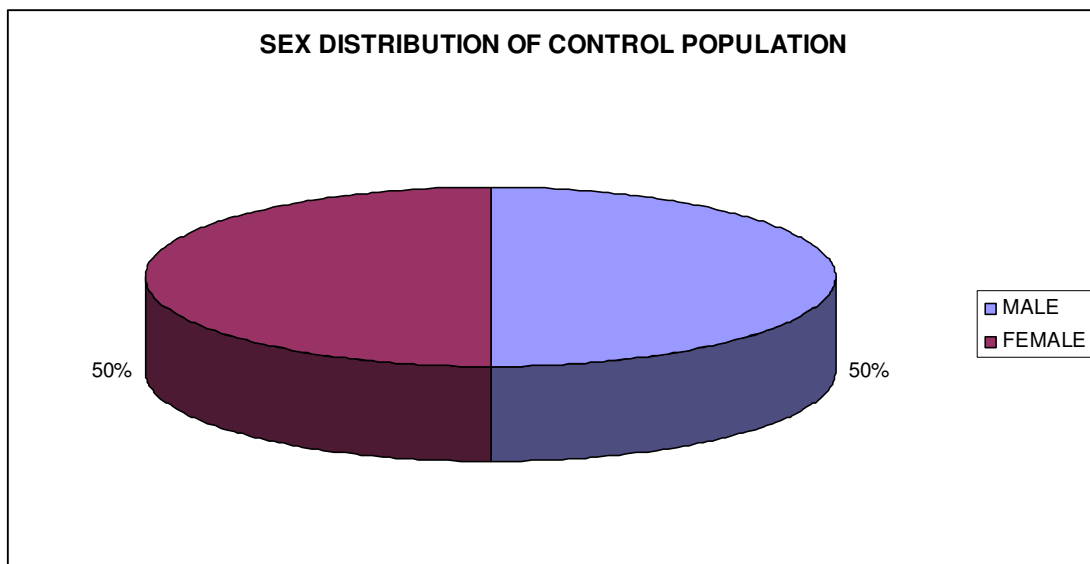

AGE AND SEX DISTRIBUTION AMONG CASES

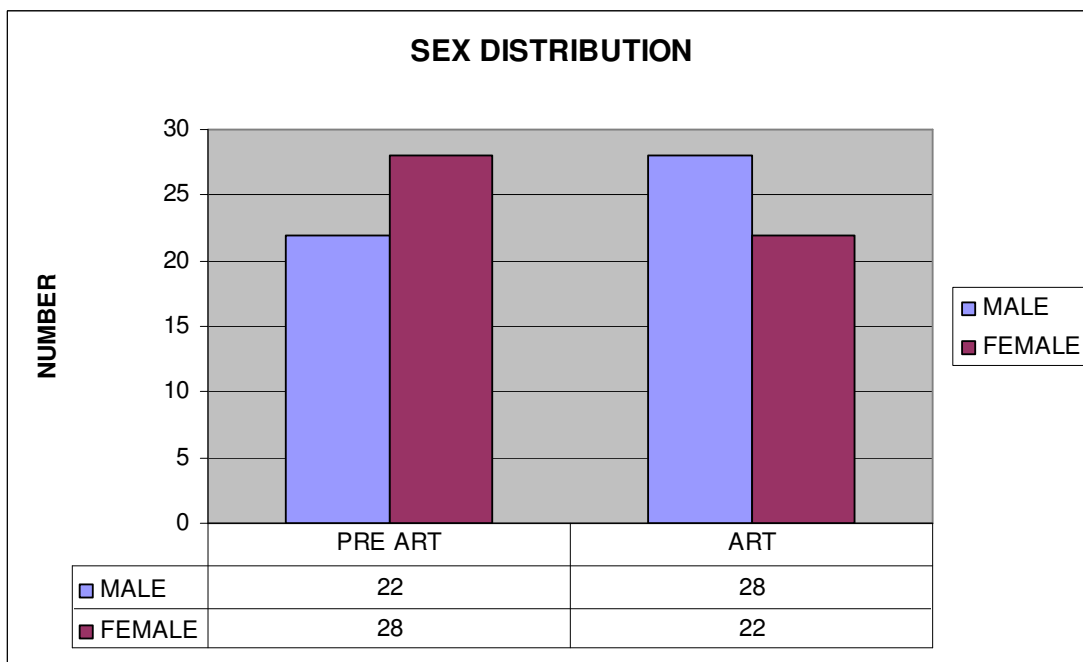
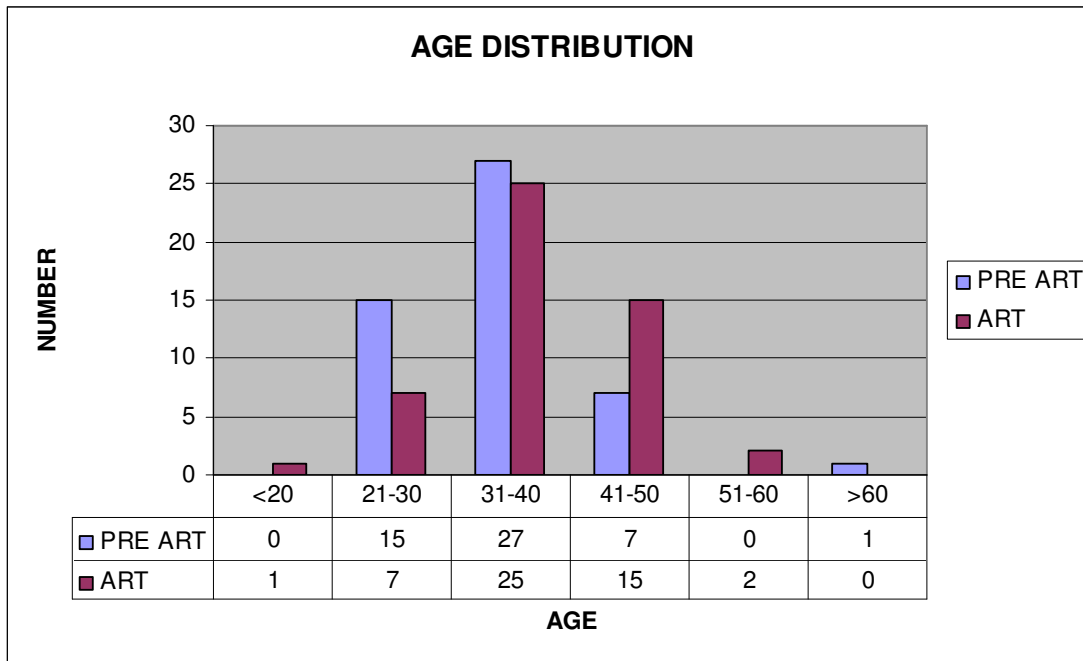

BODY MASS INDEX

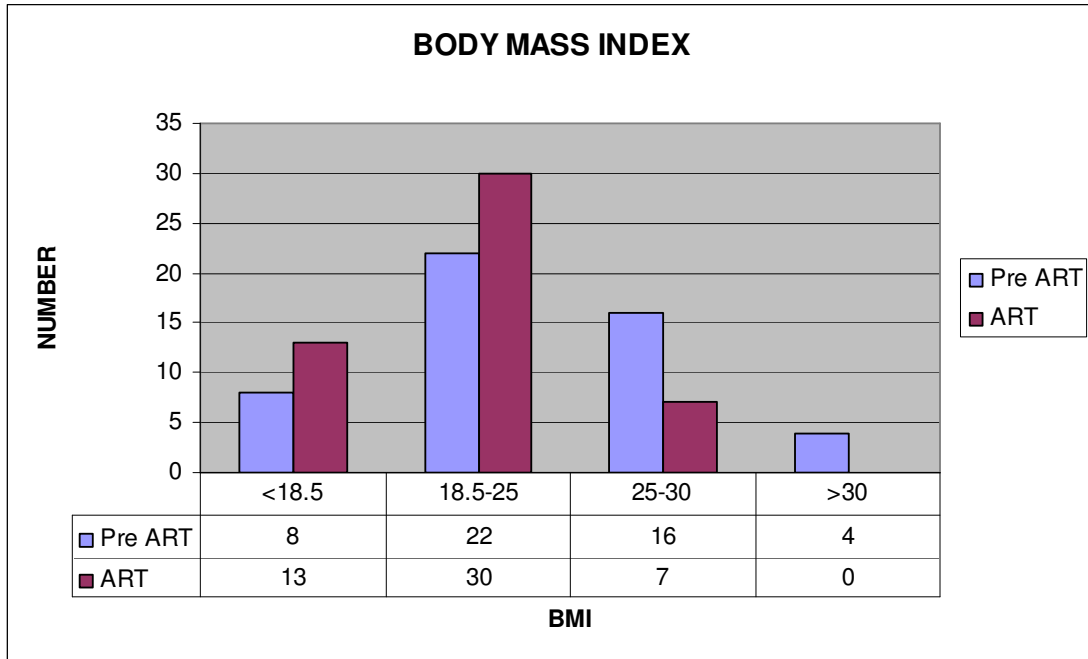

ART REGIMEN

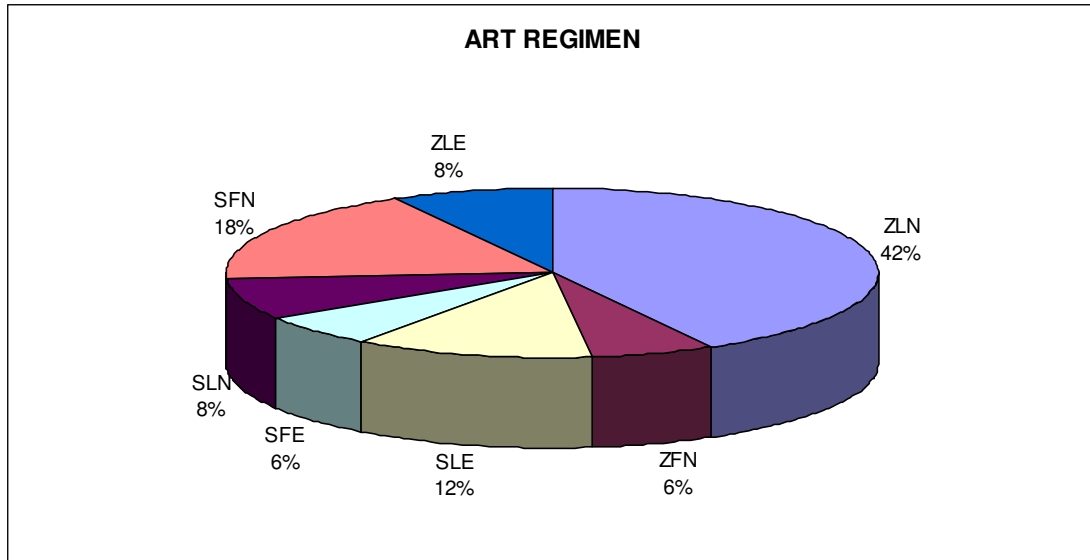

- Z - Zidovudine
- L - Lamivudine
- N - Nevirapine
- F - Emtricitabine
- E - Efavirenz
- S - Stavudine

STATISTICAL ANALYSIS

COMPARISON OF CASES AND CONTROL POPULATION

	Cases		Controls		P value
	Mean	Standard deviation	Mean	Standard deviation	
Age	35.99	8.00	36.14	7.36	0.912
BMI	22.30	4.47	22.95	3.90	0.389
Systolic BP	118.30	7.85	117.28	6.07	0.422
Diastolic BP	79.70	4.41	78.44	4.20	0.096
eGFR CG	102.30	33.37	103.92	24.04	0.761
eGFR MDRD	114.04	27.87	111.68	28.15	0.627
Microalbumin	38.07	48.78	14.28	8.35	0.001*

There is statistically significant difference in urine microalbumin level between control population and cases. There is no significant difference in Age, BMI, Systolic blood pressure, Diastolic blood pressure and eGFR calculated by Cockcroft Gault and MDRD formulae between cases and control population.

MICROALBUMINURIA AMONG CASES AND CONTROLS

		Cases	Controls
Microalbuminuria	Present	24	2
	Absent	76	48

Microalbuminuria is present in 24% of cases compared to 4% of controls with a P value by ChiSquare test of 0.002 which is statistically significant.

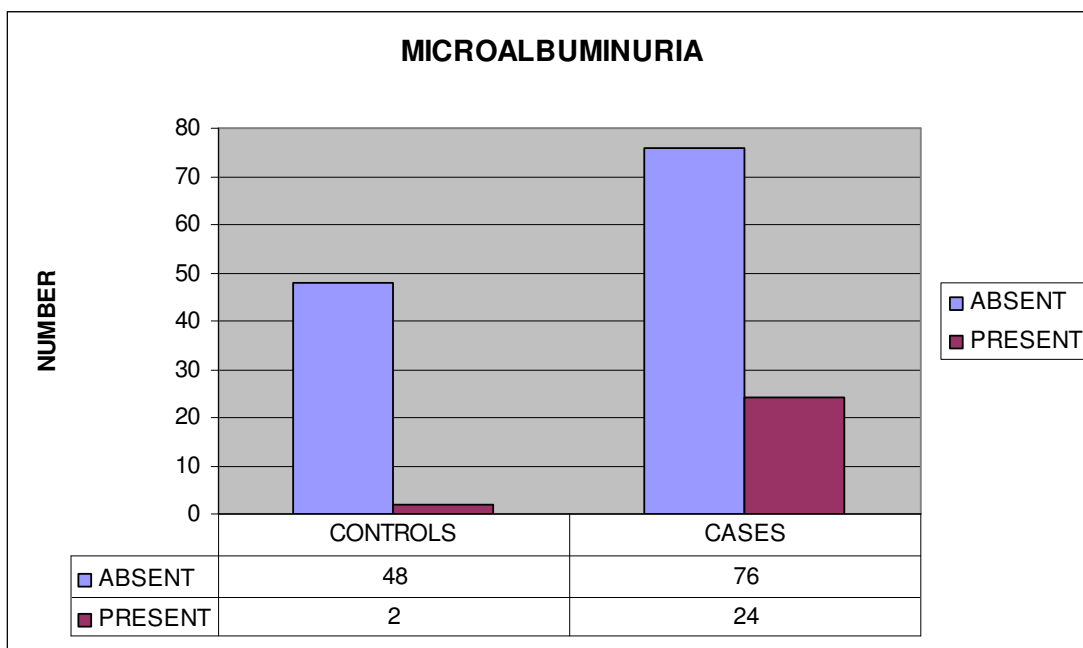

MICROALBUMINURIA AND SEX

	Urine Microalbumin	
	Mean	Standard Deviation
Male	37.15	48.46
Female	39.01	49.57

The P value for sex is 0.850 which is not statistically significant.

COMPARISON BETWEEN PRE-ART AND ART GROUPS

	Pre ART		ART		P value
	Mean	Standard deviation	Mean	Standard deviation	
Age	34.48	7.68	37.50	8.12	0.059
BMI	23.70	4.81	20.91	3.64	0.001*
Systolic BP	118.20	8.50	118.40	7.22	0.899
Diastolic BP	79.64	4.79	79.76	4.05	0.893
HIV duration	32.08	36.06	42.76	37.39	0.149
CD4 count	431.94	214.64	371.70	270.76	0.221
eGFR CG	107.77	35.56	96.84	30.47	0.102
eGFR MDRD	114.20	28.76	113.88	27.25	0.995
Microalbumin	47.74	57.44	28.41	36.31	0.047*

There is statistically significant difference in BMI and Urine microalbumin level between Pre-ART and ART groups. No significant difference is observed in Age, Systolic blood pressure, Diastolic blood pressure, Duration of HIV, CD4 count, eGFR calculated using Cockcroft-Gault and MDRD formulae between the two groups.

MICROALBUMINURIA AMONG PRE-ART AND ART GROUPS

		Pre ART	ART
Microalbuminuria	Present	17	7
	Absent	33	43

Microalbuminuria is present in 34% of Pre ART group compared to 14% in ART group with a P value by ChiSquare test of 0.041 which is statistically significant.

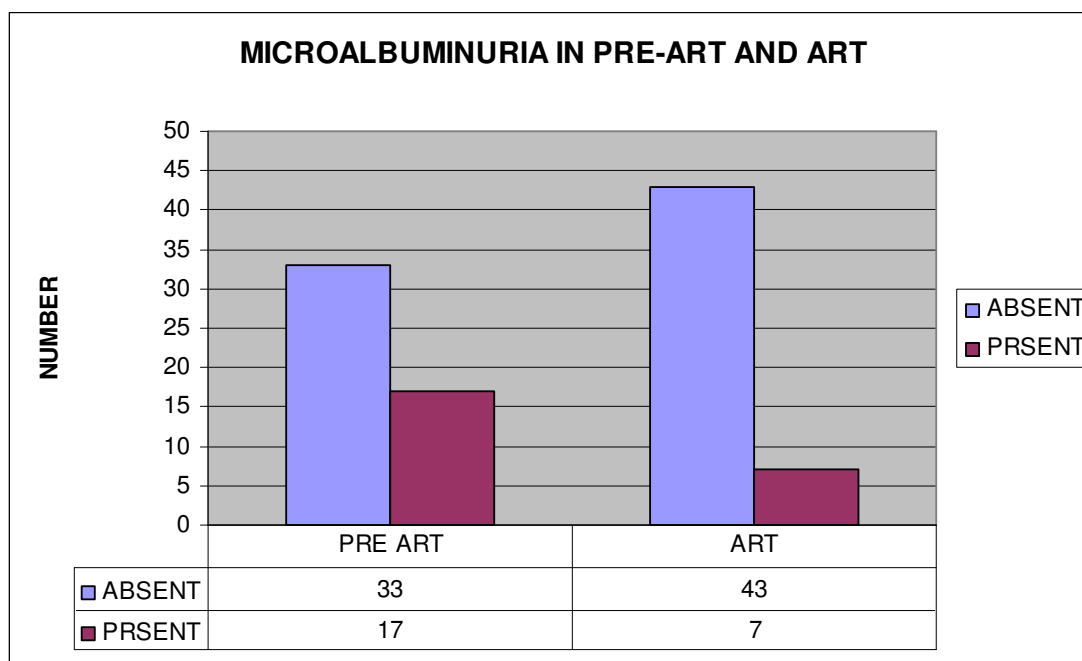

MICROALBUMINURIA AND ART REGIMEN

Regimen	Number	Microalbuminuria		Urine microalbumin	
		Present	Absent	Mean	Standard deviation
SLE	6	0	6	17.48	5.27
SFE	3	0	3	9.56	1.22
SLN	4	1	3	52.72	84.64
SFN	9	1	8	21.04	19.07
ZLE	4	0	4	14.55	3.78
ZLN	21	5	16	37.36	40.20
ZFN	3	0	3	14.70	4.68

P value by ANOVA is 0.462 and that by Chi-Square test is 0.577 which is statistically insignificant.

**COMPARISON OF PATIENTS WITH AND WITHOUT
MICROALBUMINURIA**

	Microalbuminuria negative		Microalbuminuria positive		P value
	Mean	Standard deviation	Mean	Standard deviation	
Age	35.75	7.625	36.75	9.26	0.596
BMI	22.52	4.57	21.62	4.16	0.390
Systolic BP	116.55	7.50	123.83	6.32	0.000*
Diastolic BP	79.39	4.52	80.67	3.98	0.220
Duration of HIV	32.03	30.72	54.50	48.94	0.009*
CD4 count	453.46	243.19	238.29	169.42	0.000*
eGFR CG	106.06	32.74	90.41	33.24	0.045*
eGFR MDRD	117.53	26.37	103.00	30.15	0.025*
Duration of ART	25.88	22.47	9.71	7.95	0.067

There is statistically significant difference in Systolic blood pressure, Duration of HIV, CD4 count, eGFR calculated by Cockcroft Gault and MDRD formulae between the two groups. No significant difference is observed in Age, BMI, Diastolic blood pressure and Duration of ART intake between the two groups.

MICROALBUMINURIA AND STAGE

Stage	I	II	III	IV
Microalbuminuria -ve	54	10	9	3
Microalbuminuria +ve	15	3	4	2

P value by Chi square test is 0.746 which is statistically insignificant.

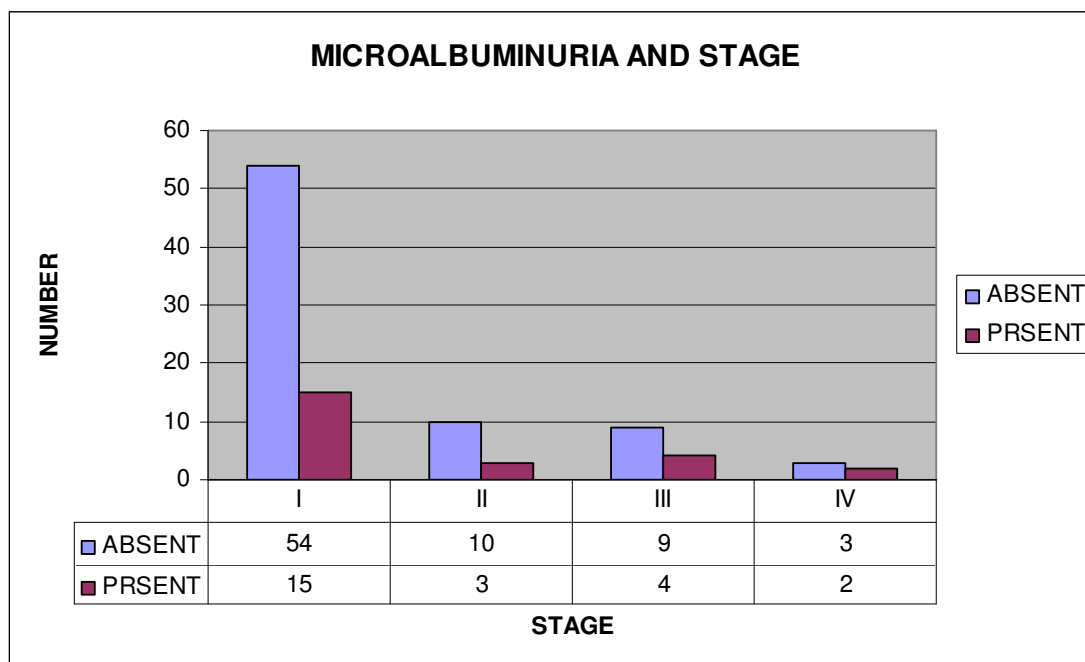

CORRELATION

	Urine Microalbumin	
	Correlation coefficient	P value
Age	0.102	0.312
BMI	-0.179	0.075
HIV duration	0.158	0.116
CD4 count	-0.506	0.000*
Systolic BP	0.338	0.001*
Diastolic BP	0.085	0.403
eGFR CG	-0.296	0.003*
eGFR MDRD	-0.290	0.003*
ART duration	-0.274	0.054

There is significant negative correlation between Urine microalbumin level and CD4 count, eGFR calculated by Cockcroft Gault and MDRD formulae. There is also a significant positive correlation between Systolic blood pressure and Urine microalbumin. No significant correlation is observed between Urine microalbumin and Age, BMI, Duration of HIV, Diastolic blood pressure and Duration of ART.

BINARY LOGISTIC REGRESSION MODEL

Dependent variable : Microalbuminuria

Independent variables : Age, Sex, BMI, Systolic blood pressure, Diastolic blood pressure, Duration of HIV, Clinical Stage, CD4 count, ART intake, Duration of ART, eGFR calculated by Cockcroft Gault and MDRD formulae.

	P value	Odds Ratio
Age	0.332	0.928
Sex	0.317	0.333
BMI	0.848	0.950
Systolic BP	0.002*	1.557
Diastolic BP	0.061	0.663
Duration of HIV	0.008*	1.050
CD4 count	0.003*	0.985
Stage	0.156	0.419
ART intake	0.005*	96.823
Duration of ART	0.100	0.945
eGFRCG	0.607	0.979
eGFRMDRD	0.978	1.001

From the above table it is evident that Systolic blood pressure, Duration of HIV, CD4 count and ART intake are independent predictors of microalbuminuria.

DISCUSSION

PREVALENCE OF MICROALBUMINURIA

The association between HIV infection and microalbuminuria based on a single urine sample has previously been observed in selected study populations in the pre-cART era, with a prevalence ranging from 19 to 34% [105-107]. In our study the prevalence was observed to be 24% though it was inclusive of population who were on ART as well.

There are many other systemic conditions causing microalbuminuria which can interfere with the prevalence. To minimize such overestimation, patients with known diabetes, hypertension or macroalbuminuria were not included in the HIV cohort or in the control group as in the study by Morten Baekken et al. [108]

The importance of taking repeated measurements has been emphasized by Romundstad et al [83], as albumin excretion may vary substantially and single-sample measurements lead to an overestimation of the true prevalence of microalbuminuria. This was not done in our study as it is a cross-sectional study and follow up was not attempted.

MICROALBUMINURIA AND SEX

Sex predilection has been noticed in studies predicting microalbuminuria [109]. Szczech et al [110] has observed female gender as a

significant predictor of microalbuminuria. No such sex predilection was observed in our study

MICROALBUMINURIA AND BODY MASS INDEX

Body mass index has been observed as a favourable predictor of microalbuminuria ^[109]. But in contrast our study did not demonstrate any association between body mass index and microalbuminuria.

MICROALBUMINURIA AND BLOOD PRESSURE

Blood pressure has been demonstrated as a major determinant of albumin excretion in other populations^[111,112] and in an HIV-infected cohort^[108,110]. In our study systolic blood pressure was observed to be associated with microalbuminuria. But no association was found between diastolic blood pressure and microalbuminuria.

MICROALBUMINURIA AND DURATION OF HIV

Serum beta 2-microglobulin, an inflammatory marker of HIV Immunoactivity^[113], emerged as an independent predictor for urinary albumin excretion. This novel finding may suggest that other pathophysiological mechanisms beyond the haemodynamic effect may be linked to microalbuminuria in the HIV-infected state. This is further supported by the observation that subjects with microalbuminuria had

longer durations of HIV infection than those without microalbuminuria^[108]. The same inference was observed in our study.

MICROALBUMINURIA AND STAGE

Prior studies demonstrated associations between the presence of microalbuminuria and ‘stage’ of HIV-infection^[106,109]. But in contrast to this our study showed no association between clinical stage of the disease and microalbuminuria.

MICROALBUMINURIA AND CD4 COUNT

Studies have found that HIV RNA level, CD4 lymphocyte count, and African–American race were important determinants of overt proteinuria^[114] and were associated with higher ACR^[110]. Our study too showed significant association between CD4 count and microalbuminuria. Measurement of HIV RNA level was not undertaken in our study.

MICROALBUMINURIA AND ART

No association was observed between the use of cART and Microalbuminuria in results by Szczech et al^[110] and Morten Baekken et al.^[108]. Nor were there significant differences between the duration of cART and microalbuminuria^[108]. In our study the

microalbuminuria was significantly decreased in HIV cohort on cART when compared to those not on ART though no association was found between duration of cART and microalbuminuria.

MICROALBUMINURIA AND DRUGS

A relationship between microalbuminuria and current use of NNRTI was noted but was not as strong as the association of microalbuminuria with other measures^[110]. While certain antiretroviral medications have been associated with acute renal failure and nephrolithiasis^[115-118], glomerular damage has not previously been reported with those medications and they were not apparently associated with microalbuminuria in this study. Tenofovir use was very low at the time of this study and indinavir use was not associated with microalbuminuria.

Our study did not demonstrate any significant association of microalbuminuria with ART regimen. However none of our patients were on Tenofovir or any of the protease inhibitors.

MICROALBUMINURIA AND RENAL FUNCTION

Microalbuminuria was observed to be linked to renal function in the study by Morten Baekken et al^[108]. In contrast, Szczech et al found no difference in serum creatinine or GFR in microalbuminuric compared to

normoalbuminuric HIV-infected individuals^[110]. On the other hand, in a selected South African HIV cohort where persistent microalbuminuric patients underwent renal biopsy, six out of seven (86%) patients had HIVAN. Microalbuminuria was found to constitute 24% of all patients with HIVAN and hence should be considered an early indicator of renal disease. Interestingly however, these patients had normal renal function^[14].

In our study eGFR was found to be significantly reduced in patients with microalbuminuria though multivariable analysis did not show significant association. A variety of renal diseases may occur and constitute an increasingly frequent complication during the course of HIV infection^[119], hence the presence of microalbuminuria cannot be neglected.

Post-Mortem studies in New York have shown nearly one-third of 89 kidney tissue donors having chronic kidney disease, and evidence of some renal pathology was found in 75. The most common diagnoses were arterionephrosclerosis, HIV-associated nephropathy and glomerulonephritis. Other diagnoses included pyelonephritis, interstitial nephritis, diabetic nephropathy, fungal infection and amyloidosis. Over one-third of the cases would have been predicted using current diagnostic criteria for chronic kidney disease. Based on semi-quantitative analysis of

stored specimens, pre-mortem microalbuminuria testing could have identified an additional 12 cases^[120].

Also, as studies have shown high prevalence of renal dysfunction in patients yet to be started on ART^[109], screening of patients for microalbuminuria becomes much more vital for early detection of HIV induced renal dysfunction that too when Tenofovir is being recommended as a first line ART which is nephrotoxic.

Studies have demonstrated the association of microalbuminuria with all cause mortality in HIV and also graded relationship between the degree of microalbuminuria and risk of mortality^[121]. Also it is the harbinger of future risk of Cardiovascular and kidney disease. Given the analogous case scenario of decrement in microalbuminuria with agents that disrupt the Renin Angiotensin axis, similar therapeutic use in HIV is plausible.

Hence the present study recommends routine screening of all HIV infected individuals for microalbuminuria especially those with increased duration of HIV infection and low CD4 counts. A follow up of patients is also suggested to detect persistent microalbuminuria. Further studies can be planned to explore the plausibility of renal biopsy in patients with persistent microalbuminuria and early initiation of ART and exploring modalities to retard the progression of renal dysfunction.

LIMITATIONS OF THE STUDY

- 1.** The sample size is small consisting of 50 controls and 100 cases.
- 2.** The study was conducted in Rajiv Gandhi Government General Hospital, Chennai which is not a representative population of the whole state or country.
- 3.** This is a cross-sectional study and hence follow up study was not attempted.
- 4.** Renal biopsy was not performed in any of the patients due to ethical reasons.
- 5.** Though most of the patients were found to be on Cotrimoxazole prophylaxis which causes an increase in serum creatinine values, they were included in the study.

CONCLUSION

The following conclusions could be arrived based on this study.

- The prevalence of microalbuminuria is significantly higher in HIV cohorts compared to control population.
- Duration of HIV infection, CD4 count and Systolic blood pressure are significant predictors of microalbuminuria.
- Microalbuminuria can be an indicator of renal dysfunction in HIV infected individuals.
- There is no significant predictive value for Age, Sex, Body mass index, Clinical stage and Diastolic blood pressure in predicting microalbuminuria.
- There is significant decrease in the prevalence of microalbuminuria in patients on ART compared to those not started on ART.
- There is no significant association between duration of ART or individual ART regimen with microalbuminuria.

This study observes the need for routine screening of microalbuminuria, early ART initiation and plan future studies on renal biopsy for patients with persistent microalbuminuria and therapeutic trials to retard the progression of renal dysfunction.

BIBLIOGRAPHY

- [1]. Anthony S. Fauci, H. Clifford Lane, Human Immunodeficiency Virus Disease: AIDS and Related Disorders, Harrison's Principles of Internal Medicine – 18th Edition.
- [2]. Jeremy S. Leventhal, MD, & Michael J. Ross, MD, HIV-associated nephropathy, Current Diagnosis & Treatment Nephrology and Hypertension – 1st edition.
- [3]. Declining morbidity and mortality among patients with advanced human immunodeficiency virus infection. Palella FJ Jr, Delaney KM, Moorman AC, et al., NEJM 1998;338:853-860.
- [4]. The changing incidence of AIDS events in patients receiving highly active antiretroviral therapy. d'Arminio Monforte A, Sabin CA, Phillips A, et al. Archives of Internal Medicine 2005;165:416-423.
- [5]. Current management challenges in HIV: tolerability of antiretrovirals and metabolic complications. Hicks C, Currier J, Sax P, et al. AIDS Patient Care STDS 2003;17:221-233.
- [6]. Bozzette SA, Ake CF, Tam HK, Chang SW, Louis TA. Cardiovascular and cerebrovascular events in patients treated for human immunodeficiency virus infection. NEJM 2003; 348:702–710.

- [7]. The Data Collection on Adverse Events of Anti-HIV Drugs (DAD) Study Group. Combination antiretroviral therapy and the risk of myocardial infarction. *NEJM* 2003; 349:1993–2003.
- [8]. Hillege HL, Fidler V, Diercks GF, van Gilst WH, de Zeeuw D, van Veldhuisen DJ, et al. Urinary albumin excretion predicts cardiovascular and noncardiovascular mortality in general population. *Circulation* 2002; 106(14):1777–1782.
- [9]. James MA, Fotherby MD, Potter JF. Screening tests for microalbuminuria in non-diabetic elderly subjects and their relation to blood pressure. *Clinical Science* 1995; 88:185–190.
- [10]. Mattock MB, Morrish NJ, Viberti G, Keen H, Fitzgerald AP, Jackson G, et al. Prospective Study of microalbuminuria as predictor of mortality in NIDDM. *Diabetes* 1992; 41:736–741.
- [11]. Roest M, Banga JD, Janssen WM, Grobbee DE, Sixma JJ, de Jong PE, et al. Excessive urinary albumin levels are associated with future cardiovascular mortality in postmenopausal women. *Circulation* 2001; 103:3057–3061.
- [12]. Urinary albumin excretion, cardiovascular disease, and endothelial dysfunction in non-insulin-dependent diabetes mellitus. Stehouwer CD, Nauta JJ, Zeldenrust GC, et al. *Lancet* 1992;340:319-323.

- [13]. Mechanism of albuminuria associated with cardiovascular disease and kidney disease. Russo LM, Comper WD, Osicka TM . Kidney International Supplement 2004:S67-S68.
- [14]. A cross-sectional study of HIV-seropositive patients with varying degrees of proteinuria in South Africa. Han TM, Naicker S, Ramdial PK, et al .Kidney International 2006;69:2243-2250.
- [15]. HIV/AIDS, Graz A. Luzzi, T.E.A. Peto, P. Goulder and C. P. Conlon, Oxford textbook of Medicine, 5th edition.
- [16]. Global summary of the AIDS epidemic, 2009. UNAIDS and World Health Organization
- [17]. Country Progress Report, March 31, 2010, UNGASS, INDIA
- [18]. Revised WHO Clinical staging and immunological classification of HIV and case definition of HIV for surveillance. 2006.
- [19]. Current Medical Diagnosis and Treatment, 2011, 50th edition.
- [20]. Antiretroviral therapy for HIV infection in adults and adolescents, Recommendations for a public health approach, 2010 revision, World Health Organization.
- [21]. Guidelines for the Use of Antiretroviral Agents in HIV-1-Infected Adults and Adolescents, October 14, 2011, HHS Panel on Antiretroviral Guidelines for Adults and Adolescents.

- [22]. Philippe Lesavre, Alex M. Davison . Infection related glomerulonephritis, Oxford textbook of Clinical Nephrology, 3rd edition.
- [23]. D'Agati, V. and Appel, G. B. (1998). Renal pathology of human immunodeficiency virus infection. *Seminars in Nephrology* 18, 406-421.
- [24]. D'Agati, V. et al. (1989). Pathology of HIV-associated nephropathy: a detailed morphologic and comparative study. *Kidney International* 35, 1358-1370.
- [25]. Halpern, M. et al. (1992). Renal aspergilloma: an unusual cause of infection in a patient with acquired immunodeficiency syndrome. *American Journal of Medicine* 92, 437-440.
- [26]. Scherr, G. R., Evans, S. G., Kiyabu, M. T., and Klatt, E. C. (1992). *Archives of Pathology and Laboratory Medicine* 116, 535-536.
- [27]. Santos, J. et al. (1994). Isolated renal mucormycosis in two AIDS patients. *European Journal of Clinical Microbiology and Infectious Diseases* 13, 430-432.
- [28]. Green, W. R., Greaves, W. L., Frederick, W. R., and Taddesse-Heath, L. (1994). Renal infection due to adenovirus in a patient with human immunodeficiency virus infection. *Clinical Infectious Diseases* 18, 989-991.

- [29]. Kimmel PL. Clinical and immunopathogenic aspects of HIV-associated renal diseases. In: Nielson EG, Couser W. Immunologic renal disease. New York: Lippincott.
- [30]. Bourgoignie JJ. Renal complications of human immunodeficiency virus type I. *Kidney International* 1990;37:1571.
- [31]. Kimmel PL. The nephropathies of HIV infection: pathogenesis and treatment. *Current Opinion in Nephrology and Hypertension* 2000;9:117.
- [32]. Klotman PE. HIV-associated nephropathy. *Kidney International* 1999;56:1161.
- [33]. D'Agati V, Appel GB. HIV infection and the kidney. *Journal of the American Society of Nephrology* 1997;8:138.
- [34]. Glassock RJ, Cohen AH, Danovitch G, Parsa KP: Human immunodeficiency virus (HIV) infection and the kidney. *Annals of Internal Medicine* 1990; 112:35-49.
- [35]. Liu R, Paxton WA, Choe S, et al: Homozygous defect in HIV-1 coreceptor accounts for resistance of some multiply-exposed individuals to HIV-1 infection. *Cell* 1996; 86:367-377.
- [36]. Bourgoignie JJ, Ortiz-Interian C, Green DF: The human immunodeficiency virus epidemic and HIV associated nephropathy. In: Hatano M, ed. *Nephrology*, 1st ed. Tokyo: Springer Verlag; 1990:484-492.

- [37]. Rao TK, Friedman EA, Nicastrì AD: The types of renal disease in the acquired immunodeficiency syndrome. *NEJM* 1987; 316:1062-1068.
- [38]. Strauss J, Abitbol C, Zilleruelo G, et al: Renal disease in children with the acquired immunodeficiency syndrome. *NEJM* 1989; 321:625-630.
- [39]. Bruggeman LA, Ross MD, Tanji N, et al: Renal epithelium is a previously unrecognized site of HIV-1 infection. *Journal of the American Society of Nephrology* 2000; 11:2079-2087.
- [40]. Zuo Y et al: HIV-1 genes vpr and nef synergistically damage podocytes, leading to glomerulosclerosis. *Journal of the American Society of Nephrology* 2006;17:2832.
- [41]. Shankland SJ, Eitner F, Hudkins KL, et al: Differential expression of cyclin-dependent kinase inhibitors in human glomerular disease: Role in podocyte proliferation and maturation. *Kidney International* 2000; 58:674-683.
- [42]. Cohen AH, Nast CC. HIV-associated nephropathy. A unique combined glomerular, tubular and interstitial lesion. *Modern Pathology* 1988;1:87.
- [43]. Gardenswartz MH, Lerner CW, Seligson GR, et al: Renal disease in patients with AIDS: a clinicopathologic study. *Clinical Nephrology* 1984; 21: 197-204.

- [44]. Langa C, Gallo GR, Schacht RG, et al: Rapid renal failure in AIDS-associated focal glomerulosclerosis. *Archives of Internal Medicine* 1990; 150:287-292.
- [45]. Marras D, Bruggeman LA, Gao F, et al: Replication and compartmentalization of HIV-1 in kidney epithelium of patients with HIV-associated nephropathy. *Nature Medicine* 2002; 8:522-526.
- [46]. Pardo V, Meneses R, Ossa L, et al: AIDS-related glomerulopathy: Occurrence in specific risk groups. *Kidney Int* 1987; 31:1167-1173.
- [47]. Humphreys MH: Human immunodeficiency virus-associated glomerulosclerosis. *Kidney International* 1995; 48:311-320.
- [48]. Ross MJ, Klotman PE: Recent progress in HIV-associated nephropathy. *Journal of the American Society of Nephrology* 2002; 13:2997-3004.
- [49]. Barisoni L, Kriz W, Mundel P, D'Agati V: The dysregulated podocyte phenotype: A novel concept in the pathogenesis of collapsing idiopathic focal segmental glomerulosclerosis and HIV-associated nephropathy. *Journal of the American Society of Nephrology* 1999; 10:51-61.
- [50]. Valeri A, Neusy AJ: Acute and chronic renal disease in hospitalized AIDS patients. *Clinical Nephrology* 1991; 35:110-118.

- [51]. Bourgoignie JJ, Meneses R, Ortiz C, et al: The clinical spectrum of renal disease associated with human immunodeficiency virus. *American Journal of Kidney Diseases* 1988; 12:131-137.
- [52]. Ifudu, O. et al. (1995). Zidovudine is beneficial in human immunodeficiency virus associated nephropathy. *American Journal of Nephrology* 15, 217-221.
- [53]. Michel, C. et al. (1992). Nephropathy associated with infection by human immunodeficiency virus: a report on 11 cases including 6 treated with zidovudine. *Nephron* 62, 434-440.
- [54]. Atta M et al: Antiretroviral therapy in the treatment of HIV-associated nephropathy. *Nephrology Dialysis Transplantation* 2006;21:2809.
- [55]. Scialla J et al: Relapse of HIV-associated nephropathy after discontinuing highly active antiretroviral therapy. *AIDS* 2007;21(2):263.
- [56]. Wali, R. K. et al. (1998). HIV-1-associated nephropathy and response to highly-active antiretroviral therapy. *Lancet* 352, 783-784.
- [57]. Winston, J. A. et al. (2001). Nephropathy and establishment of a renal reservoir of HIV type 1 during primary infection. *New England Journal of Medicine* 344, 1979-1984.
- [58]. Bird JE, Durham SK, Giancarli MR, et al. Captopril prevents nephropathy in HIV-transgenic mice. *Journal of the American Society of Nephrology* 1998;9:1441.

- [59]. Kimmel, P. L., Mishkin, G. J., and Umana, W. O. (1996). Captopril and renal survival in patients with human immunodeficiency virus nephropathy. *American Journal of Kidney Diseases* 28, 202-208.
- [60]. Burns, G. C. et al. (1997). Effect of angiotensin-converting enzyme inhibition in HIV-associated nephropathy. *Journal of the American Society of Nephrology* 8, 1140-1146.
- [61]. Kumar MSA, Sierka DR, Damask AM, et al: Safety and success of kidney transplantation and concomitant immunosuppression in HIV-positive patients. *Kidney International* 2005 ; 67:1622-1629.
- [62]. Long-term patient and graft survival after kidney transplantation in hiv positive patients. *Transplantation* 2006; 82: 121-122.
- [63]. Bhagani S, Sweny P, Brook G: Guidelines for kidney transplantation in patients with HIV disease. *HIV Medicine* 2006; 7: 133-139.
- [64]. Bodi I, Kimmel PL, Abraham AA, et al. Renal TGF-beta in HIV-associated kidney diseases. *Kidney International* 1997;51:1568.
- [65]. Kimmel PL, Bosch JP, Vassalotti JA. Treatment of human immunodeficiency virus-associated nephropathy. *Seminar on Nephrology* 1998;18:446.
- [66]. Ross MJ et al: HIV-1 infection initiates an inflammatory cascade in human renal tubular epithelial cells. *Journal of Acquired Immune Deficiency Syndrome* 2006;42(1):1.

- [67]. Appel RG, Neill J. A steroid-responsive nephrotic syndrome in a patient with human immunodeficiency virus infection. *Annals of Internal Medicine* 1990;113:892.
- [68]. Briggs WA, Tanawattanacharoen S, Choi MJ, et al. Clinicopathologic correlates of prednisone treatment of human immunodeficiency virus-associated nephropathy. *American Journal of Kidney Diseases* 1996;28:618.
- [69]. Watterson MK, Detwiler RK, Bolin JP. Clinical response to prolonged corticosteroids in a patient with human immunodeficiency virus-associated nephropathy. *American Journal of Kidney Diseases* 1997;29:624.
- [70]. Smith MC, Austen JL, Carey JT, et al. Prednisone improves renal function and proteinuria in human immunodeficiency virus-associated nephropathy. *American Journal of Medicine* 1996;101:41.
- [71]. Bhagani S, Sweny P, Brook G: Guidelines for kidney transplantation in patients with HIV disease. *HIV Medicine* 2006 ; 7:133-139.
- [72]. Casanova S, Mazzucco G, Barbiano DB, et al: Pattern of glomerular involvement in human immunodeficiency virus- infected patients: An Italian study. *American Journal of Kidney Diseases* 1995; 26: 446-453.

- [73]. Kimmel PL, Phillips TM, Ferreira-Centeno A, et al: HIV-associated immune-mediated renal disease. *Kidney International* 1993; 44:1327-1340.
- [74]. Kopp JB, et al. Crystalluria and urinary tract abnormalities associated with indinavir. *Annals of Internal Medicine* 1997;127:119.
- [75]. Jaradat M, Phillips C, Yum MN, et al. Acute tubulointerstitial nephritis attributable to indinavir therapy. *American Journal of Kidney Diseases* 2000;35: E16.
- [76]. Kimmel PL, Abraham AA, Phillips TM. Membranoproliferative glomerulonephritis in a patient treated with interferon alpha for HIV infection. *American Journal of Kidney Diseases* 1994;24:858.
- [77]. de Jong PE, Curhan GC: Screening, monitoring, and treatment of albuminuria: Public health perspectives. *Journal of the American Society of Nephrology* 17 :2120– 2126,2006
- [78]. Locatelli F, Marcelli D, Comelli M, et al. Proteinuria and blood pressure as causal components of progression to end-stage renal failure. Northern Italian Cooperative Study Group. *Nephrology Dialysis Transplantation* 1996;11:461–7.
- [79]. Selby JV, FitzSimmons SC, Newman JM, et al. The natural history and epidemiology of diabetic nephropathy: implications for prevention and control. *JAMA* 1990;263:1954–60.

- [80]. Gerstein HC, Mann JF, Yi Q, et al. Albuminuria and risk of cardiovascular events, death, and heart failure in diabetic and nondiabetic individuals. *JAMA* 2001;286:421–6.
- [81]. Beamer NB, Coull BM, Clark WM, et al. Microalbuminuria in ischemic stroke. *Archives of Neurology* 1999;56:699–702.
- [82]. Donnelly R, Rea R. Microalbuminuria: how informative and reliable are individual measurements? *Journal of Hypertension* 2003;21:1229–33.
- [83]. Romundstad S, Holmen J, Kvenild K, et al. Microalbuminuria and all-cause mortality in 2,089 apparently healthy individuals: a 4.4 year follow-up study. The Nord-Trøndelag Health Study (HUNT), Norway. *American Journal of Kidney Diseases* 2003;42:466–73.
- [84]. Borch-Johnsen K, Feldt-Rasmussen B, Strandgaard S, et al. Urinary albumin excretion: an independent predictor of ischemic heart disease. *Arteriosclerosis, Thrombosis and Vascular Biology* 1999;19:1992–7.
- [85]. Roest M, Banga JD, Janssen WM, et al. Excessive urinary albumin levels are associated with future cardiovascular mortality in postmenopausal women. *Circulation* 2001;103:3057–61.
- [86]. Jager A, Kostense PJ, Ruhe HG, et al. Microalbuminuria and peripheral arterial disease are independent predictors of cardiovascular and all-cause mortality, especially among hypertensive subjects: five-year follow-up of the Hoorn Study. *Arteriosclerosis, Thrombosis and Vascular Biology* 1999;19:617–24.

[87]. Jensen JS, Feldt-Rasmussen B, Strandgaard S, et al. Arterial hypertension, microalbuminuria, and risk of ischemic heart disease. *Hypertension* 2000;35:898–903.

[88]. Dinneen SF, Gerstein HC. The association of microalbuminuria and mortality in non-insulin dependent diabetes mellitus: a systematic overview of the literature. *Archives of Internal Medicine* 1997;157:1413–18.

[89]. Stehouwer CD, Gall M-A, Twisk JW, et al. Increased urinary albumin excretion, endothelial dysfunction, and chronic low-grade inflammation in type II diabetes: progressive, interrelated, and independently associated with risk of death. *Diabetes* 2002;51:1157–62.

[90]. Ralf Dikow, Eberhard Ritz *The patient with diabetes mellitus, Oxford Textbook of Clinical Nephrology, 3rd Edition*

[91]. Deckert T, Feldt-Rasmussen B, Borch-Johnsen K, Jensen T, Kofoed-Enevoldsen A: Albuminuria reflects widespread vascular damage. The Steno hypothesis. *Diabetologia* 32 :219– 226,1989

[92]. Stehouwer CD, Henry RM, Dekker JM, Nijpels G, Heine RJ, Bouter LM: Microalbuminuria is associated with impaired brachial artery, flow-mediated vasodilation in elderly individuals without and with diabetes: Further evidence for a link between microalbuminuria and endothelial dysfunction—The Hoorn Study. *Kidney International Supplement* 92 :S42– S44,2004

- [93]. Stehouwer CD, Smulders YM: Microalbuminuria and risk for cardiovascular disease: Analysis of potential mechanisms. *Journal of the American Society of Nephrology* 17 :2106– 2111,2006
- [94]. Jager A, van H, V, Kostense PJ, Emeis JJ, Nijpels G, Dekker JM, Heine RJ, Bouter LM, Stehouwer CD: C-reactive protein and soluble vascular cell adhesion molecule-1 are associated with elevated urinary albumin excretion but do not explain its link with cardiovascular risk. *Arteriosclerosis, Thrombosis and Vascular Biology* 22 :593– 598,2002
- [95]. Schram MT, Chaturvedi N, Schalkwijk CG, Fuller JH, Stehouwer CD: Markers of inflammation are cross-sectionally associated with microvascular complications and cardiovascular disease in type 1 diabetes: The EURODIAB Prospective Complications Study. *Diabetologia* 48 :370– 378,2005
- [96]. Jensen JS, Borch-Johnsen K, Jensen G, Feldt-Rasmussen B: Microalbuminuria reflects a generalized transvascular albumin leakiness in clinically healthy subjects. *Clinical Science (Lond)*88 :629– 633,1995
- [97]. Nosadini R, Velussi M, Brocco E, Abaterusso C, Piarulli F, Morgia G, Satta A, Faedda R, Abhyankar A, Luthman H, Tonolo G: Altered transcapillary escape of albumin and microalbuminuria reflects two different pathogenetic mechanisms. *Diabetes* 54 :228– 233,2005

- [98]. de Zeeuw D, Parving HH, Henning RH: Microalbuminuria as an early marker for cardiovascular disease. *Journal of the American Society of Nephrology* 17 :2100– 2105,2006
- [99]. Brantsma AH, Bakker SJ, Hillege HL, de Zeeuw D, de Jong PE, Gansevoort RT: Urinary albumin excretion and its relation with C-reactive protein and the metabolic syndrome in the prediction of type 2 diabetes. *Diabetes Care* 28 :2525– 2530,2005
- [100]. Comper WD, Jerums G, Osicka TM: Differences in urinary albumin detected by four immunoassays and high-performance liquid chromatography. *Clinical Biochemistry* 37 :105– 111,2004
- [101]. Mattix HJ, Hsu CY, Shaykevich S, Curhan G: Use of the albumin/creatinine ratio to detect microalbuminuria: Implications of sex and race. *Journal of the American Society of Nephrology* 13 :1034– 1039,2002
- [102]. Verhave JC, Hillege HL, de Zeeuw D, de Jong PE: How to measure the prevalence of microalbuminuria in relation to age and gender? *American Journal of Kidney Diseases* 40 :436– 437,2002
- [103]. Vilas U. Chavan, Pushpa P. Durgawale, Anjum K. Sayyed, Ajit V. Sontakke, Nazir R. Attar, Swati B. Patel, Sangita R. Patil and Shreyasprasad D. Nilakhe . A Comparative Study of Clinical Utility of Spot Urine Samples with 24-h Urine Albumin Excretion for Screening of

Microalbuminuria in Type 2 Diabetic Patients , Indian Journal of Clinical Biochemistry Volume 26, Number 3, 283-289

[104]. Matthew R. Weir, Microalbuminuria and Cardiovascular Disease, Clinical Journal of the American Society of Nephrology, February 2007

[105]. Kabanda A, Vandercam B, Bernard A, et al .Low molecular weight proteinuria in human immunodeficiency virus-infected patients. American Journal of Kidney Diseases 1996;27:803-808.

[106]. Luke DR, Sarnoski TP, Dennis S . Incidence of microalbuminuria in ambulatory patients with acquired immunodeficiency syndrome. Clinical Nephrology 1992;38:69-74.

[107]. Kimmel PL, Umana WO, Bosch JP . Abnormal urinary protein excretion in HIV-infected patients. Clinical Nephrology 1993;39:17-21.

[108]. Morten Baekken, Ingrid Os, Leiv Sandvik and Olav Oektedalen. Microalbuminuria associated with indicators of inflammatory activity in an HIV-positive population.

[109]. Msango, Leonard ,Downs, Jennifer A, Kalluvya, Samuel E, Kidenya, Benson R, Kabangila, Rodrick , Johnson, Warren D. Jr. , Fitzgerald, Daniel W. ,Peck, Robert . Renal dysfunction among HIV-infected patients starting antiretroviral Therapy. AIDS. 25(11):1421-1425, July 17, 2011.

[110]. Szczech LA, Grunfeld C, Scherzer R, 4. et al . Microalbuminuria in HIV infection. AIDS 2007;21:1003-1009.

- [111]. Damsgaard EM, Froland A, Jorgensen OD, et al. Microalbuminuria as predictor of increased mortality in elderly people. *BMJ* 1990;300:297-300.
- [112]. Yudkin JS, Forrest RD, Jackson CA. Microalbuminuria as predictor of vascular disease in non-diabetic subjects. Islington diabetes survey. *Lancet* 1988;2:530-533.
- [113]. Lacey JN, Forbes MA, Waugh MA, et al. Serum beta 2-microglobulin and human immunodeficiency virus infection. *AIDS* 1987;1:123-127.
- [114]. Szczech LA, Gange SJ, van der Horst C, Bartlett JA, Young M, Cohen MH, et al. Predictors of proteinuria and renal failure among women with HIV infection. *Kidney International* 2002; 61:195–202.
- [115]. Berns JS, Cohen RM, Silverman M, Turner J. Acute renal failure due to indinavir crystalluria and nephrolithiasis: report of two cases. *American Journal of Kidney Diseases* 1997; 30:558–560.
- [116]. Daudon M, Estepa L, Viard JP, Joly D, Jungers P. Urinary stones in HIV-1 positive patients treated with indinavir. *Lancet* 1997; 349:1294–1205.
- [117]. Karras A, Lafaurie M, Furco A, Bourgarit A, Droz D, Sereni D, et al. Tenofovir related nephrotoxicity in human immunodeficiency virus-infected patients: three cases of renal failure, Fanconi syndrome, and

nephrogenic diabetes insipidus. *Clinical Infectious Diseases* 2003; 36:1070–1073.

[118]. Creput C, Gonzalez-Canali G, Hill G, Piketty C, Kazatchkine M, Nochy D. Renal lesions in HIV-1-positive patient treated with tenofovir. *AIDS* 2003; 17:935–937.

[119]. Schwartz EJ, Szczech LA, Ross MJ, et al . Highly active antiretroviral therapy and the epidemic of HIV+ end-stage renal disease. *Journal of the American Society of Nephrology* 2005;16:2412-2420.

[120]. Christina M Wyatt; Susan Morgello; Rebecca Katz-Malamed; Catherine Wei; Mary E Klotman; Paul E Klotman ; Vivette D D'Agati. The Spectrum of Kidney Disease in Patients with AIDS in the Era of Antiretroviral Therapy. *Kidney International* Vol: 75, No: 4, February, 2 2009 [Page 428-434]

[121]. Wyatt, Christina M , Hoover, Donald R , Shi, Qiuhu , Seaberg, Eric , Wei, Catherine, Tien, Phyllis C , Karim, Roksana , Lazar, Jason , Young, Mary A, Cohen, Mardge H, Klotman, Paul E , Anastos, Kathryn . Microalbuminuria Is Associated With All-Cause and AIDS Mortality in Women With HIV Infection . *Journal of Acquired Immune Deficiency Syndromes* Issue: Volume 55(1), 1 September 2010, pp 73-77

PROFORMA

Name:

Age:

Sex:

Address:

Unit/Ward:

PRESENT HISTORY

Initial presentation

Duration of HIV

Duration of ART intake

Fever

Burning Micturition

PAST & PERSONAL H/O

Jaundice

Alcoholism

Blood Transfusion

Premarital/Extramarital contact

Tattooing/IV drug abuse

CLINICAL EXAMINATION

Anaemia

Jaundice

Pedal Oedema

Stigmata of Tuberculosis

Lymphadenopathy

Clubbing

Weight

Height

Body Mass Index

External markers of HIV infection

VITALS

Pulse rate

Blood Pressure

Respiratory rate

Temperature

SYSTEMIC EXAMINATION

Cardiovascular System

Respiratory system

Abdomen

Central Nervous System

INVESTIGATIONS:

URINE ANALYSIS

Albumin

Sugar

Deposits

Urine Microalbumin concentration

COMPLETE HEMOGRAM

Hb (g/dL)

TC (cells/cmm)

DC

RBC(millions/cmm)

Platelet(Lakhs/cmm)

PCV

RENAL FUNCTION TESTS

Blood Sugar(mg/dL)

Blood Urea(mg/dL)

S. Creatinine(mg/dL)

ECG in all leads

Chest X ray PA view

USG Abdomen

Sputum smear for Acid fast bacilli

HbsAg

Anti HCV

CD4 count

eGFR (Calculated using Cockcroft Gault and MDRD formulae)

PATIENT CONSENT FORM

Study detail:

“PREVALENCE AND PREDICTORS OF MICROALBUMINURIA IN HIV INFECTED INDIVIDUALS”

Study centre : Rajiv Gandhi Government General Hospital, Chennai.

Patients Name :

Patients Age :

Identification Number :

Patient may check (✓) these boxes

I confirm that I have understood the purpose of procedure for the above study. I have the opportunity to ask question and all my questions and doubts have been answered to my complete satisfaction.

I understand that my participation in the study is voluntary and that I am free to withdraw at any time without giving reason, without my legal rights being affected.

I understand that sponsor of the clinical study, others working on the sponsor's behalf, the ethical committee and the regulatory authorities will not need my permission to look at my health records, both in respect of current study and any further research that may be conducted in relation to it, even if I withdraw from the study I agree to this access. However, I understand that my identity will not be revealed in any information released to third parties or published, unless as required under the law. I agree not to restrict the use of any data or results that arise from this study.

I agree to take part in the above study and to comply with the instructions given during the study and faithfully cooperate with the study team and to immediately inform the study staff if I suffer from any deterioration in my health or well being or any unexpected or unusual symptoms.

I hereby consent to participate in this study.

I hereby give permission to undergo complete clinical examination and diagnostic tests including hematological, biochemical, radiological tests.

Signature/thumb impression:

Patients Name and Address: Place Date

Signature of investigator :

Study investigator's Name: Place Date

INSTITUTIONAL ETHICS COMMITTEE
MADRAS MEDICAL COLLEGE, CHENNAI -3

Telephone No: 04425305301
Fax : 044 25363970

CERTIFICATE OF APPROVAL

To
Dr. Vignesh Kumar. C
PG in MD General Medicine
Madras Medical College, Chennai -3.

Dear Dr. Vignesh Kumar. C

The Institutional Ethics Committee of Madras Medical College reviewed and discussed your application for approval of the proposal entitled "Prevalance and predictors of microalbuminuria in HIV infected individuals" No. 10042011.

The following members of Ethics Committee were present in the meeting held on 21.04.2011 conducted at Madras Medical College, Chennai -3.

- | | |
|------------------------------------------------------------------------------------|---------------------|
| 1. Prof. S.K. Rajan, MD | -- Chairperson |
| 2. Prof. V. Kanagasabai MD
Dean, Madras Medical College, Chennai-3, | -- Deputy chairman |
| 3. Prof. A. Sundaram, MD
Vice Principal , Madras Medical College, Chennai -3 | -- Member Secretary |
| 4. Prof R. Sathianathan MD | -- Member |
| 5. Prof R. Nandhini, MD
Director, Institute of Pharmacology, MMC, Ch-3 | -- Member |
| 6. Prof. Pregna B. Dolia MD
Director , Institute of Biochemistry, MMC, Ch-3 | -- Member |
| 7. Prof. C. Rajendiran .MD
Director , Institute of Internal Medicine, MMC, Ch-3 | -- Member |
| 8. Thiru. A. Ulaganathan
Administrative Officer, MMC, Chennai -3 | -- Layperson |
| 9. Thiru. S. Govindasamy . BA.BL | -- Lawyer |
| 10. Tmt. Arnold Soulina | -- Social Scientist |

We approve the proposal to be conducted in its presented form.

Sd / . Chairman & Other Members

The Institutional Ethics Committee expects to be informed about the progress of the study, any SAE occurring in the course of the study, any changes in the protocol and patient information / informed consent and asks to be provided a copy of the final report

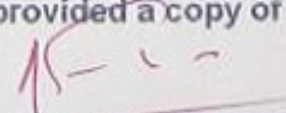
Member Secretary, Ethics Committee

MASTER CHART OF PRE-ART CASES															
SERIAL NO.	AGE (years)	SEX	WEIGHT (kg)	HEIGHT (cm)	BMI (kg/m ²)	Systolic BP	Diastolic BP	HIV duration (months)	CD4 count (cells/cu.mm)	STAGE	S.CREATININE (mg/dl)	CREATININE CLEARANCE (ml/min)	eGFR(ml/min)	MICROALBUMINURIA	MICROALBUMIN (mg/l)
1	38	F	55	148	25.1	114	82	12	315	1	0.8	82.79	85	A	22.1
2	33	F	48	154	20.2	116	80	96	581	4	0.7	86.62	102	A	10.7
3	32	F	57	152	24.7	112	80	0	475	1	0.7	103.8	103	A	12.4
4	33	F	65	154	27.4	110	74	60	466	1	0.6	136.8	122	A	11.8
5	31	F	70	154	29.5	106	70	72	579	1	0.7	128.7	104	A	17.1
6	30	F	56	152	24.2	100	76	0	479	1	0.8	90.9	90	A	15.3
7	28	F	54	155	22.5	110	72	0	457	1	0.7	102	106	A	12.2
8	35	F	45	158	18	108	82	7	441	1	0.8	69.72	87	A	10.9
9	32	F	52	158	20.8	114	76	3	369	1	0.7	94.71	103	A	13.4
10	29	F	45	152	19.5	106	74	6	598	1	0.6	98.28	126	A	8.7
11	30	F	80	152	34.6	118	82	28	377	2	0.5	207.7	154	A	15.6
12	28	F	58	158	23.2	106	70	1	319	1	0.7	109.6	106	A	20.2
13	25	F	55	152	23.8	104	70	42	449	1	0.7	106.7	108	A	15.4
14	33	F	60	152	26	110	74	1	403	1	0.5	151.6	151	A	16.2
15	47	F	83	145	39.5	122	84	1	757	1	0.8	113.9	82	A	6.7
16	28	F	61	146	28.6	114	70	30	934	1	0.6	134.4	127	A	4.9
17	40	F	40	150	17.8	114	80	23	760	1	0.6	78.7	118	A	5.8
18	36	F	75	157	30.4	124	80	38	721	1	0.7	131.5	101	A	7.8
19	29	F	55	137	29.3	110	72	19	598	1	0.6	120.1	126	A	11.2
20	38	F	55	147	25.5	122	82	18	484	1	0.7	94.61	100	A	16.8
21	40	M	62	162	23.6	122	84	0	93	1	0.8	107.6	114	A	24.6
22	25	M	41	157	16.6	114	78	5	801	3	0.8	81.85	125	A	9.4
23	40	M	45	159	17.8	120	84	8	371	1	0.8	78.12	114	A	17.2
24	27	M	65	169	22.8	136	88	0	308	4	0.8	127.5	123	A	19.3
25	38	M	75	172	25.4	126	84	6	541	1	0.7	151.7	134	A	14.3

MASTER CHART OF PRE-ART CASES															
SERIAL NO.	AGE (years)	SEX	WEIGHT (kg)	HEIGHT (cm)	BMI (kg/m2)	Systolic BP	Diastolic BP	HIV duration (months)	CD4 count (cells/cu.mm)	STAGE	S.CREATININE (mg/dl)	CREATININE CLEARANCE (ml/min)	eGFR(ml/min)	MICROALBUMINURIA	MICROALBUMIN (mg/l)
26	31	M	57	155	23.7	124	80	2	357	3	1	86.26	93	A	10.5
27	29	M	70	165	25.7	110	82	41	510	1	0.6	179.9	169	A	9.7
28	45	M	70	163	26.3	114	80	1	314	1	0.5	184.7	191	A	15.8
29	38	M	60	158	24	120	80	38	524	1	0.7	121.4	134	A	16.6
30	32	M	45	146	21.1	112	80	72	711	1	0.9	75	104	A	8.4
31	23	M	57	171	19.5	116	82	24	399	2	0.9	102.9	111	A	16.3
32	48	M	62	154	26.1	126	84	18	895	1	0.6	132	153	A	5.6
33	36	M	75	172	25.4	122	82	19	541	1	0.7	154.8	136	A	10.7
34	31	F	53	151	23.2	126	84	38	584	1	0.8	85.25	89	P	38.9
35	25	F	35	141	17.6	128	86	24	380	1	0.9	52.49	81	P	82.7
36	36	F	40	153	17.1	126	84	86	180	1	0.8	61.38	86	P	108.5
37	45	F	46	156	18.9	124	80	90	123	3	0.6	85.98	115	P	142.7
38	25	F	30	140	15.3	116	72	3	68	4	2	25.45	42	P	201.4
39	43	F	57	147	26.4	122	80	96	438	1	0.8	81.59	83	P	92.5
40	31	F	45	140	23	112	76	42	281	2	0.6	96.51	124	P	100.4
41	31	F	70	150	31.1	114	76	156	283	1	0.7	128.7	104	P	103.2
42	32	M	65	150	28.9	130	82	39	374	1	0.7	139.3	139	P	95.5
43	65	M	58	155	24.1	136	88	82	81	3	1	43.15	54	P	187.4
44	45	M	45	164	16.7	130	84	124	96	4	0.8	74.21	111	P	177.7
45	43	M	54	160	21.1	118	80	4	85	1	1	72.75	87	P	180.3
46	34	M	57	170	19.7	116	84	1	147	2	0.6	139.9	164	P	138.9
47	31	M	62	168	22	130	82	23	182	1	0.9	104.3	105	P	152.4
48	38	M	65	160	25.4	124	80	39	524	1	0.8	115.1	115	P	42.7
49	36	M	60	150	26.7	134	84	48	610	1	0.7	123.8	136	P	40.8
50	26	M	50	160	19.5	122	82	18	234	1	0.6	131.9	173	P	67.4

SERIAL NO.	AGE (years)	SEX	WEIGHT (kg)	HEIGHT (cm)	BMI (kg/m ²)	Systolic BP	MASTER CHART OF ART CASES					S.CREATININE (mg/dl)	CREATININE CLEARANCE (ml/min)	eGFR(ml/min)	MICROALBUMINURIA	ART REGIMEN	MICROALBUMIN (mg/l)
							Diastolic BP	HIV duration (months)	ART duration (months)	CD4 count (cells/cu.mm)	STAGE						
1	35	F	31	142	15.4	108	74	7	7	274	3	0.8	48.03	87	A	SLE	21.1
2	34	F	48	161	18.5	122	80	58	36	709	1	0.8	75.08	87	A	SFE	8.5
3	29	F	55	155	22.9	118	82	60	22	852	1	0.7	103	105	A	SFN	7.2
4	32	F	55	166	20	110	72	67	67	766	2	0.7	100.2	103	A	SFN	7.3
5	46	F	45	150	19.6	124	82	2	2	340	3	1	49.93	63	A	SFN	15.7
6	28	F	50	157	20.3	110	78	60	40	791	1	0.8	82.63	91	A	SFN	6.9
7	57	F	40	147	18.5	128	86	60	12	272	1	0.9	43.54	69	A	ZLE	18.9
8	36	F	51	147	23.6	114	72	31	20	381	1	0.8	78.27	86	A	ZLN	16.4
9	44	F	58	162	22.1	120	84	48	12	322	2	0.7	93.9	97	A	ZLN	16.6
10	35	F	60	164	22.3	106	76	58	58	890	1	0.8	92.96	87	A	ZLN	5.9
11	24	F	50	152	21.6	100	72	64	3	285	1	0.5	136.9	161	A	ZLN	23.2
12	43	F	64	152	27.7	122	82	3	3	109	3	0.6	122.1	116	A	ZLN	24.4
13	34	F	65	150	28.9	112	78	34	6	249	2	0.5	162.7	150	A	ZLN	20.7
14	37	F	53	150	23.6	116	82	48	30	274	1	0.7	92.06	100	A	ZLN	19.9
15	34	F	66	149	29.7	104	74	31	31	549	1	0.7	118	102	A	ZFN	12.3
16	45	F	41	160	16	118	84	64	34	624	1	0.6	76.63	115	A	ZFN	11.7
17	21	F	41	150	18.2	104	70	1	1	134	3	0.7	82.28	112	A	SLE	21.1
18	42	F	43	145	20.5	118	80	2	2	65	1	0.5	99.49	144	A	SFN	24.3
19	36	M	36	154	15.2	120	78	24	24	391	1	0.8	101.1	116	A	SLE	18.7
20	30	M	50	160	19.5	120	78	24	24	158	1	0.6	135	168	A	SLE	20.9
21	32	M	45	162	17.1	114	80	19	19	662	1	0.8	84.37	119	A	SLE	15.4
22	36	M	60	155	25	126	84	60	55	1247	1	0.8	108.3	116	A	SLE	7.7
23	46	M	70	161	27	122	84	72	72	852	1	0.6	152.3	154	A	SFE	9.3
24	41	M	43	162	16.4	118	78	73	72	355	2	0.7	84.46	132	A	SFE	10.9
25	14	M	31	142	15.4	100	74	168	6	300	2	0.9	62.22	117	A	SLN	10.1

SERIAL NO.	AGE (years)	SEX	WEIGHT (kg)	HEIGHT (cm)	BMI (kg/m ²)	Systolic BP	MASTER CHART OF ART CASES					S.CREATININE (mg/dl)	CREATININE CLEARANCE (ml/min)	eGFR(ml/min)	MICROALBUMINURIA	ART REGIMEN	MICROALBUMIN (mg/l)
							Diastolic BP	HIV duration (months)	ART duration (months)	CD4 count (cells/cu.mm)	STAGE						
26	42	M	75	172	25.4	122	82	60	52	745	1	0.6	170.1	157	A	SLN	6.8
27	41	M	37	142	18.3	118	80	72	12	370	2	0.7	72.67	132	A	SLN	14.4
28	48	M	55	165	20.2	124	84	60	15	96	1	0.5	140.6	189	A	SFN	23.8
29	35	M	60	174	19.8	120	82	62	62	151	1	0.7	131	136	A	SFN	21.1
30	48	M	60	169	21	120	78	8	4	323	3	0.8	95.83	110	A	SFN	14.7
31	40	M	55	163	20.7	122	80	26	26	403	1	0.7	109.1	133	A	ZLE	15.8
32	38	M	50	150	22.2	122	78	1	1	245	4	0.9	78.7	100	A	ZLE	13.6
33	56	M	50	169	17.5	128	86	72	44	435	2	0.7	83.33	124	A	ZLE	9.9
34	37	M	60	159	23.7	112	82	48	48	239	1	1	85.83	89	A	ZLN	17.9
35	31	M	72	162	27.4	116	82	49	49	409	1	0.7	155.7	140	A	ZLN	11.6
36	40	M	62	164	23.1	118	84	3	3	93	1	0.8	107.6	114	A	ZLN	22.8
37	47	M	40	140	20.4	126	84	2	1	160	1	0.9	57.4	96	A	ZLN	14.8
38	37	M	60	162	22.9	124	80	4	4	181	1	1	78.03	80	A	ZLN	18.7
39	40	M	55	154	23.2	128	86	8	8	645	3	0.8	95.48	114	A	ZLN	8.4
40	34	M	40	165	14.7	116	80	37	36	203	3	0.7	84.12	137	A	ZLN	13.8
41	37	M	50	158	20	120	78	31	28	277	1	0.6	119.2	161	A	ZLN	14.5
42	31	M	55	166	20	122	82	60	60	642	1	0.8	104.1	120	A	ZFN	20.1
43	37	M	50	166	18.1	124	84	2	2	68	2	0.9	79.47	101	A	ZLN	24.6
44	34	F	35	148	16	130	80	12	12	71	1	0.8	54.74	87	P	SLN	179.6
45	35	F	52	157	21.1	120	82	17	17	159	1	0.7	92.08	101	P	ZLN	147.8
46	28	F	55	150	24.4	120	72	80	23	296	1	0.9	80.8	79	P	ZLN	114.5
47	30	F	40	154	16.9	122	76	28	4	266	2	0.8	64.93	90	P	ZLN	100.9
48	43	M	45	150	20	122	80	6	3	67	3	1	60.62	87	P	SFN	68.4
49	48	M	55	160	21.5	130	82	180	2	49	3	0.5	140.6	110	P	ZLN	57.8
50	47	M	71	178	22.4	120	80	72	7	141	1	0.8	114.6	110	P	ZLN	89.5

SERIAL NO.	AGE (years)	SEX	WEIGHT (kg)	MASTER CHART OF CONTROLS				S.CREATININE (mg/dl)	CREATININE CLEARANCE (ml/min)	eGFR (ml/min)	MICROALBUMIN (mg/l)	MICROALBUMINURIA
				HEIGHT (cm)	BMI (kg/m ²)	Systolic BP	Diastolic BP					
1	38	F	58	154	24.45	122	76	0.7	99.77	100	11.7	A
2	36	F	49	156	20.13	120	82	0.8	75.2	86	18.1	A
3	34	F	61	149	27.47	114	72	0.7	109.04	102	7.3	A
4	42	M	64	161	24.69	120	80	0.6	145.18	157	14.4	A
5	43	F	51	158	20.42	116	70	0.7	83.43	97	0.8	A
6	47	M	58	165	21.3	124	84	1	74.91	85	36.8	P
7	36	M	44	151	19.29	120	78	0.9	70.61	101	13.8	A
8	35	F	63	157	25.55	118	80	0.7	111.56	101	21.1	A
9	28	M	54	167	19.36	122	82	0.6	140	171	3.4	A
10	16	M	47	159	18.59	118	84	0.6	134.9	187	9.8	A
11	27	M	54	168	20.08	124	82	0.8	105.93	123	14.6	A
12	65	M	60	158	24.03	134	84	1.1	56.81	71	49.1	P
13	46	M	68	168	24.09	120	78	0.9	98.64	97	15.6	A
14	35	F	54	157	21.9	122	84	0.8	83.67	87	20.1	A
15	35	F	64	149	28.82	118	78	0.7	113.33	101	9.8	A
16	34	F	71	155	29.55	112	76	0.6	148.08	122	0.9	A
17	31	F	58	149	26.12	108	78	0.7	106.62	104	19.8	A
18	28	F	57	154	24.03	110	72	0.6	125.61	127	12.2	A
19	30	M	55	170	19.03	120	82	0.8	105.03	121	8.3	A
20	38	F	55	157	22.31	114	78	0.8	82.78	85	17.4	A
21	43	M	56	172	18.92	126	80	1	75.44	87	16.1	A
22	30	F	55	148	25.1	114	78	0.8	89.27	90	11.3	A
23	41	M	56	164	20.82	120	80	1	77	88	6.4	A
24	40	M	47	152	20.34	116	78	0.8	89.75	114	22.1	A
25	44	M	54	165	19.83	122	84	0.5	144	192	18.3	A

SERIAL NO.	AGE (years)	SEX	WEIGHT (kg)	MASTER CHART OF CONTROLS				S.CREATININE (mg/dl)	CREATININE CLEARANCE (ml/min)	eGFR (ml/min)	MICROALBUMIN (mg/l)	MICROALBUMINURIA
				HEIGHT (cm)	BMI (kg/m ²)	Systolic BP	Diastolic BP					
26	36	F	46	156	18.9	116	80	0.7	80.68	101	13.4	A
27	27	F	80	155	33.29	118	70	0.8	133.4	91	5.2	A
28	37	F	74	151	32.45	110	72	0.8	112.47	86	7.9	A
29	47	M	54	161	20.83	122	80	1	69.75	85	8.3	A
30	33	F	55	158	22.03	126	70	0.7	99.25	102	12.6	A
31	32	M	47	159	18.59	114	76	0.7	100.71	139	12.3	A
32	36	F	48	153	20.5	116	82	0.8	73.66	86	16.8	A
33	35	M	56	168	19.84	118	80	0.7	116.66	136	11.3	A
34	36	F	54	157	21.9	112	78	0.6	110.5	120	3.8	A
35	46	F	54	152	23.37	122	82	0.5	119.85	141	7.8	A
36	28	M	63	167	22.58	112	80	0.7	140	143	15.6	A
37	36	M	72	169	25.2	120	82	0.8	130	116	23.4	A
38	31	F	45	151	19.73	108	74	0.7	82.72	104	12.5	A
39	32	F	76	148	34.69	110	72	0.8	121.12	88	16.6	A
40	35	M	57	156	23.42	118	78	0.6	138.54	163	4.5	A
41	37	F	36	145	17.12	102	74	0.6	72.95	120	6.2	A
42	34	M	69	166	25.03	110	80	0.7	145.11	137	21.1	A
43	37	F	58	157	23.53	104	82	0.7	100.75	100	12.3	A
44	44	M	70	168	24.8	124	84	1	93.33	86	17.4	A
45	38	M	54	164	20.07	116	82	0.8	95.62	115	11.6	A
46	27	F	56	156	23.01	122	70	0.7	106.72	107	14.4	A
47	39	M	72	168	25.51	118	82	0.9	112.22	100	18.6	A
48	32	M	55	172	18.59	110	78	0.7	117.85	139	19.2	A
49	38	M	56	163	21.07	118	80	0.8	99.16	115	23.2	A
50	32	F	60	154	25.29	124	74	1	76.5	68	19.1	A